



 **Primary 5 Science (Term 2) - Nanyang** [Add Questions](#)[Assign](#)[Settings](#)[Review](#)[Duplicate](#)[Print](#)[Delete](#)[Assign Test](#)**Test Introduction**[+ Add Introduction](#)**66 Questions** (70 Points)Question Bank: 9,275 Questions 

Test Questions

0 Test Assignments

Question 1

Primary 5 Science » Primary 5 Science (Term 2)

2 pts

For each question, four options are given. One of them is the correct answer. Make your choice (A, B, C or D) and choose the correct answer. (28 x 2 marks)

The diagram below shows a bird's nest fern.



A single fern produces thousands of spores. Each spore has the ability to grow into an adult plant.

Which one of the following best explains why the fern needs to produce a large number of spores?

- A) To ensure the fern will grow more fruits.
- B) To ensure the fern can carry out wind pollination.
- C) To ensure the young plants can grow well together.
- D) To ensure some of the spores will grow into adult plants.

Question Type: Multiple Choice
Randomize Answers: No
Date Added: Thu 5th Aug 2021
Last Modified: N/A
QID#: 28,628,083

[Answers](#) | [Edit](#) | [Duplicate](#) | [Used In](#) | [Reorder](#)

[Remove From Test](#)

Question 2

Primary 5 Science » Primary 5 Science (Term 2)

2 pts

The diagram below shows fruit S.

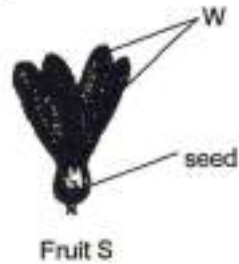

Yusof carried out an experiment with the fruit. He used one fruit S with 4 parts W and released the fruit from the same height above the ground and recorded the distance travelled from the starting point to the point the fruit landed on the ground. He then removed part W one at a time and repeated the experiment.

Number of Part W on Fruit S	Distance travelled (m)
4	5
3	3
2	1
1	0.5

What is the aim of Yusof's experiment?

- A) To find out the longest distance Fruit S can travel.
- B) To find out how the size of the seed affects the distance Fruit S travels.
- C) To find out how the length of part W affects the distance Fruit S travels.
- ✓ D) To find out how the number of part W affects the distance Fruit S travels.

Question Type: Multiple Choice
Randomize Answers: No
Date Added: Thu 5th Aug 2021
Last Modified: N/A
QID#: 28,628,071

[Answers](#) | [Edit](#) | [Duplicate](#) | [Used In](#) | [Reorder](#)

[Remove From Test](#)

Question 3

Primary 5 Science » Primary 5 Science (Term 2)

2 pts

Which of the following should Yusof do to ensure that the experimental results are reliable?

- A Measure the length of each part W.
- B Measure the time taken for the fruit to land on the ground.
- C Repeat each of the experiment at least 3 times.**

- A) A only
- B) C only
- C) B and C only
- D) A, B and C

Question Type: Multiple Choice
Randomize Answers: No
Date Added: Thu 5th Aug 2021
Last Modified: N/A
QID#: 28,628,072

[Answers](#) | [Edit](#) | [Duplicate](#) | [Used In](#) | [Reorder](#)

[Remove From Test](#)

Question 4

Primary 5 Science » Primary 5 Science (Term 2)

2 pts

The diagram below shows processes, A, B, C and D, involved in the sexual reproduction of flowering plants.

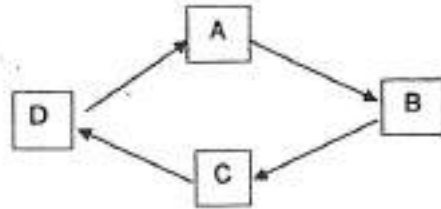

Which one of the following could represent processes A, B, C and D?

- A)

A	B	C	D
seed dispersal	fertilisation	germination	pollination
- B)

A	B	C	D
fertilisation	seed dispersal	germination	pollination
- C)

A	B	C	D
seed dispersal	pollination	germination	fertilisation
- D)

A	B	C	D
germination	seed dispersal	pollination	fertilisation

Question Type: Multiple Choice
Randomize Answers: No
Date Added: Thu 5th Aug 2021
Last Modified: N/A
QID#: 28,628,073

[Answers](#) | [Edit](#) | [Duplicate](#) | [Used In](#) | [Reorder](#)

[Remove From Test](#)

Question 5

Primary 5 Science » Primary 5 Science (Term 2)

2 pts

Which one of the following sets of statements about pollination and seed dispersal is correct?

- A)

Pollination	Seed dispersal
Pollen grains can only be transferred from the stigma to the anther by insects.	Some wind-dispersed seeds have wing-like structures.

- B)

Pollination	Seed dispersal
Pollen grains are transferred by the wind only.	All juicy fruits are dispersed by explosive action.

- ✓ C)

Pollination	Seed dispersal
Pollen grains are transferred from the anther to the stigma by wind or animals.	Fruits with fibrous husks are dispersed by water.

- D)

Pollination	Seed dispersal
Pollen grains that are sticky are transferred by animals.	Seeds that are dispersed by animals must be small.

Question Type: Multiple Choice
Randomize Answers: No
Date Added: Thu 5th Aug 2021
Last Modified: N/A
QID#: 28,628,074

[Answers](#) | [Edit](#) | [Duplicate](#) | [Used In](#) | [Reorder](#)

[Remove From Test](#)

Question 6

Primary 5 Science » Primary 5 Science (Term 2)

2 pts

The diagrams below show the reproductive parts of a flower and a female human.

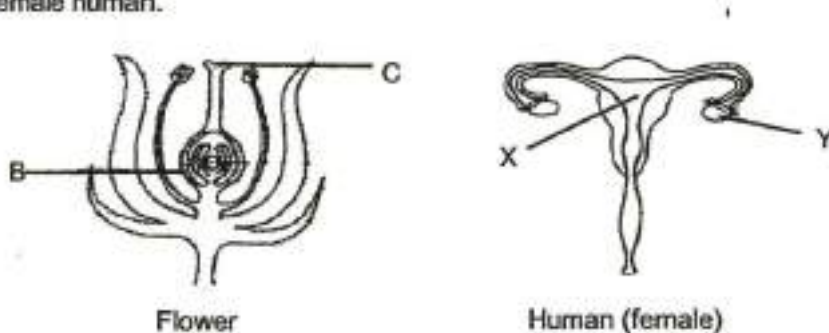

Which of the following represents the parts where the female reproductive cells are produced?

- A) B and X

- ✓ B) B and Y
- C) C and X
- D) C and Y

Question Type: Multiple Choice
Randomize Answers: No
Date Added: Thu 5th Aug 2021
Last Modified: N/A
QID#: 28,628,075

[Answers](#) | [Edit](#) | [Duplicate](#) | [Used In](#) | [Reorder](#)

[Remove From Test](#)

Question 7

Primary 5 Science » Primary 5 Science (Term 2)

2 pts

Which of the following statements about reproduction in humans are correct?

- A Many sperms are needed to fertilise the egg.
- B Fertilisation takes place inside the body of the female.
- C After fertilisation has taken place, the fertilised egg will develop into a baby.

- A) A and B only
- B) A and C only
- ✓ C) B and C only
- D) A, B and C

Question Type: Multiple Choice
Randomize Answers: No
Date Added: Thu 5th Aug 2021
Last Modified: N/A
QID#: 28,628,076

[Answers](#) | [Edit](#) | [Duplicate](#) | [Used In](#) | [Reorder](#)

[Remove From Test](#)

Question 8

Primary 5 Science » Primary 5 Science (Term 2)

2 pts

Which of the following statement(s) about the development of a human baby in the womb is/are correct?

- P The human baby developed from one fertilised egg cell.
- Q It will take more than a year for the baby to develop and be ready for birth.
- R The baby will have genetic information from only one of his or her parents.

- ✓ A) P only
- B) P and Q only
- C) Q and R only

D) P, Q and R

Question Type: Multiple Choice
Randomize Answers: No
Date Added: Thu 5th Aug 2021
Last Modified: N/A
QID#: 28,628,077

[Answers](#) | [Edit](#) | [Duplicate](#) | [Used In](#) | [Reorder](#)

[Remove From Test](#)

Question 9

Primary 5 Science » Primary 5 Science (Term 2)

2 pts

The diagram below shows a beaker filled with two substances, P and Q.

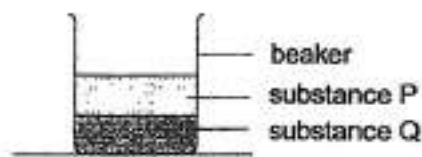

The beaker was then placed on a ramp as shown below.

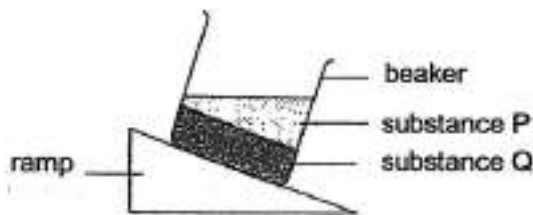

Which of the following correctly shows the states of matter that substances P and Q are in?

- A)

Substance P	Substance Q
solid	liquid
- ✓ B)

Substance P	Substance Q
liquid	solid
- C)

Substance P	Substance Q
liquid	gas
- D)

Substance P	Substance Q
gas	solid

Question Type: Multiple Choice
Randomize Answers: No
Date Added: Thu 5th Aug 2021
Last Modified: N/A
QID#: 28,628,078

Question 10

Primary 5 Science » Primary 5 Science (Term 2)

2 pts

Matthew heated a beaker of water until the water boiled as shown in the diagram below. He then turned off the flame and left the water to cool.

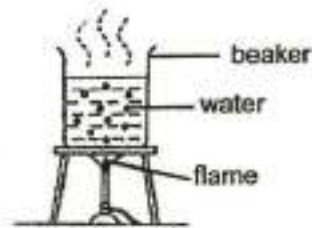

He recorded the temperature of the water and plotted a graph as shown below.

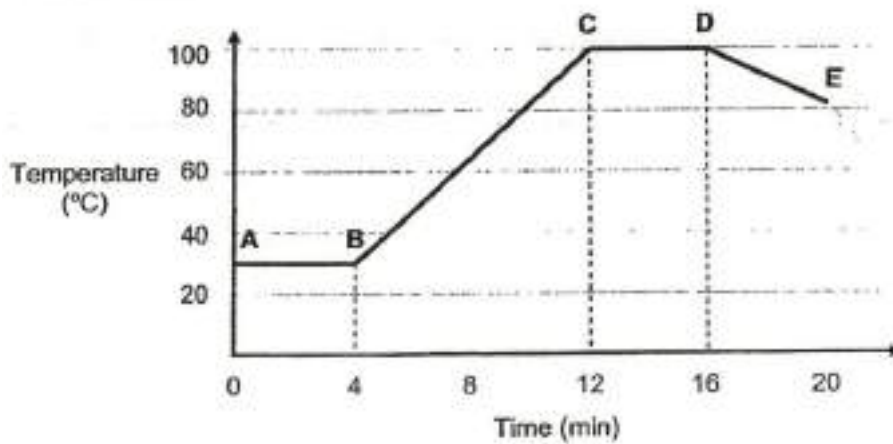

Based on the above experiment, which one of the following statements is correct?

- ✓ A) The water lost heat between DE.
- B) Water changed state during BC only.
- C) The water started boiling at 4 minutes.
- D) The water was in the solid state at the start of the experiment.

Question Type: Multiple Choice
Randomize Answers: No
Date Added: Thu 5th Aug 2021
Last Modified: N/A
QID#: 28,628,079

Question 11

Primary 5 Science » Primary 5 Science (Term 2)

2 pts

Jie Ying heated two beakers of water, X and Y, at room temperature with the same amount of heat as shown in the diagram below.

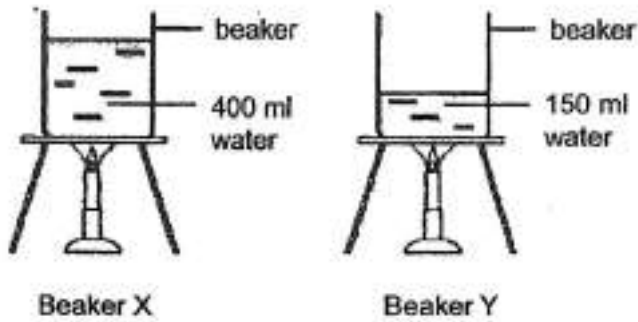

Which of the following statement(s) about the two beakers of water is/are correct?

- A) Both beakers of water would boil at the same time.
- B) Both beakers of water would have the same temperature when they boil
- C) The boiling water in Beaker X would have a greater amount of heat than the boiling water in Beaker Y.

- A) A only
- B) A and B only
- ✓ C) B and C only
- D) A, B and C

Question Type: Multiple Choice
Randomize Answers: No
Date Added: Thu 5th Aug 2021
Last Modified: N/A
QID#: 28,628,080

[Answers](#) | [Edit](#) | [Duplicate](#) | [Used In](#) | [Reorder](#)

[Remove From Test](#)

Question 12

Primary 5 Science » Primary 5 Science (Term 2)

2 pts

Which one of the following graphs correctly shows the effect of increased exposed surface area on the rate of evaporation?

- A)

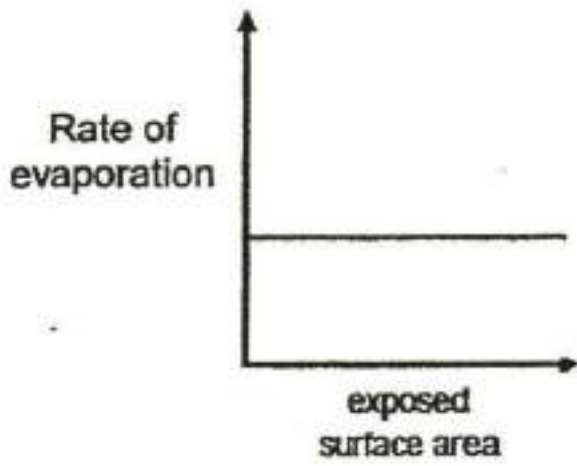

✓ B)

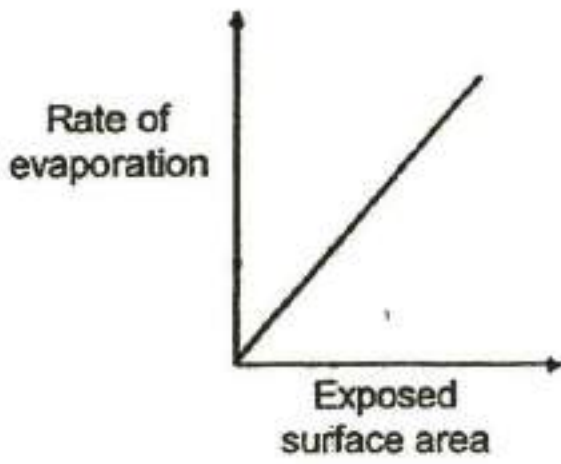

C)

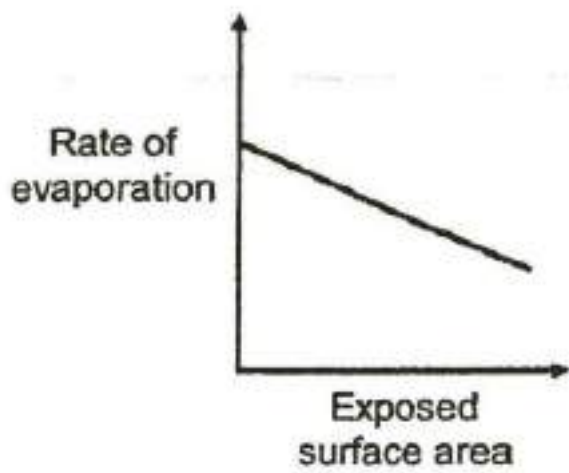

D)

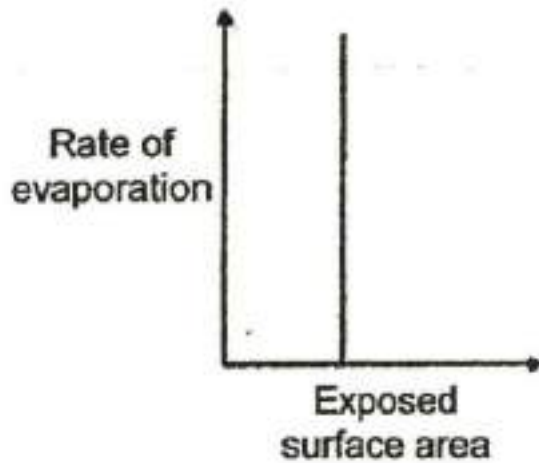

Question Type: Multiple Choice
Randomize Answers: No
Date Added: Thu 5th Aug 2021
Last Modified: N/A
QID#: 28,628,081

[Answers](#) | [Edit](#) | [Duplicate](#) | [Used In](#) | [Reorder](#)

[Remove From Test](#)

Question 13

Primary 5 Science » Primary 5 Science (Term 2)

2 pts

Rahim set up a model as shown in the diagram below to represent the water cycle.

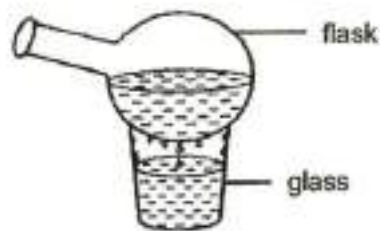

In order for this model to work, which one of the following conditions must be met?

- A) Keep the temperature of the water in the glass and flask at 100°C.
- B) Keep the temperature of the air around the set-up lower than the temperature of the water in the glass.
- C) Keep the temperature of the water in the flask higher than the temperature of the water in the glass.
- ✓ D) Keep the temperature of the water in the glass higher than the temperature of the water in the flask.

Question Type: Multiple Choice
Randomize Answers: No

Date Added: Thu 5th Aug 2021
 Last Modified: N/A
 QID#: 28,628,082

[Answers](#) | [Edit](#) | [Duplicate](#) | [Used In](#) | [Reorder](#)

[Remove From Test](#)

Question 14

Primary 5 Science » Primary 5 Science (Term 2)

2 pts

In which of the following would water go through evaporation or condensation?

- A Hanging a wet towel out to dry.
- B Making ice cubes in the freezer.
- C Water droplets forming on a cold glass surface.

A)

Evaporation	Condensation
A	B

✓ B)

Evaporation	Condensation
A	C

C)

Evaporation	Condensation
B	A

D)

Evaporation	Condensation
B	C

Question Type: Multiple Choice
 Randomize Answers: No
 Date Added: Thu 5th Aug 2021
 Last Modified: N/A
 QID#: 28,628,084

[Answers](#) | [Edit](#) | [Duplicate](#) | [Used In](#) | [Reorder](#)

[Remove From Test](#)

Question 15

Primary 5 Science » Primary 5 Science (Term 2)

2 pts

The diagram below shows three rays of light, P, Q and R.

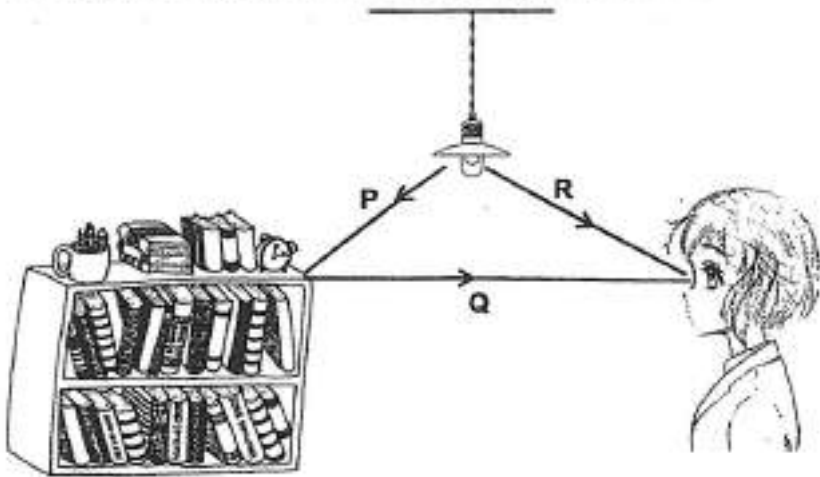

When Linda switched on the lamp in her room, she could see the lamp and the bookcase.

Which ray(s) of light best explain(s) why Linda was able to see the lamp and the bookcase?

- ✓ A)

To see the lamp	To see the bookcase
R	P and Q
- B)

To see the lamp	To see the bookcase
P	R and Q
- C)

To see the lamp	To see the bookcase
P and R	Q
- D)

To see the lamp	To see the bookcase
Q and R	P

Question Type: Multiple Choice
Randomize Answers: No
Date Added: Thu 5th Aug 2021
Last Modified: N/A
QID#: 28,628,085

[Answers](#) | [Edit](#) | [Duplicate](#) | [Used In](#) | [Reorder](#)

[Remove From Test](#)

Question 16

Primary 5 Science » Primary 5 Science (Term 2)

2 pts

Arushi set up an experiment with 4 set-ups, W, X, Y and Z, as shown in the diagram below.

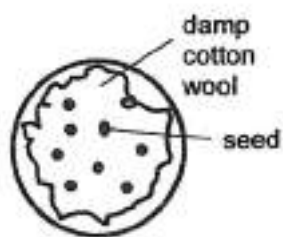

Set-up W
Placed next to the window

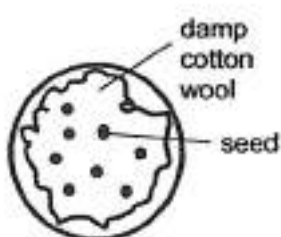

Set-up X
Placed in the cupboard

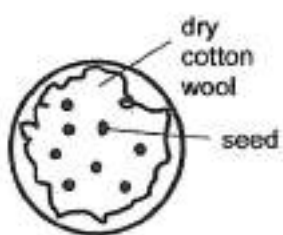

Set-up Y
Placed next to the window

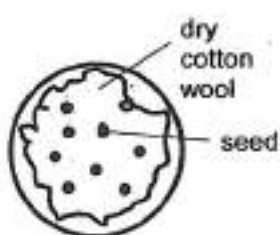

Set-up Z
Placed in the cupboard

In which of the following set-up(s) will the seeds germinate after a week?

- ✓ A) W and X only
- B) W and Y only
- C) X and Z only
- D) Y and Z only

Question Type: Multiple Choice
Randomize Answers: No
Date Added: Thu 5th Aug 2021
Last Modified: N/A
QID#: 28,628,086

[Answers](#) | [Edit](#) | [Duplicate](#) | [Used In](#) | [Reorder](#)

[Remove From Test](#)

Question 17

Primary 5 Science » Primary 5 Science (Term 2)

2 pts

The diagram below shows how the thickness of material A affects the amount of light passing through it.

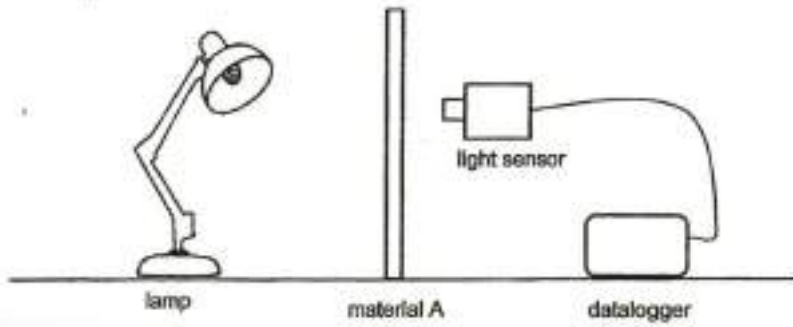

The graph below shows the results obtained.

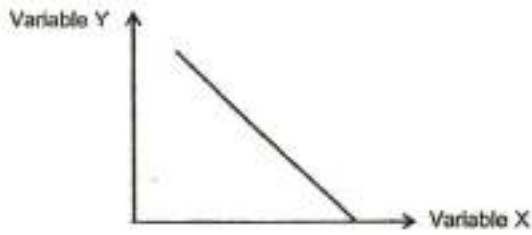

Based on the above experiment, what could Variables X and Y most likely be?

- ✓ A)

Variable X	Variable Y
Thickness of material A	Amount of light passing through material A
- B)

Variable X	Variable Y
Amount of light passing through material A	Thickness of material A
- C)

Variable X	Variable Y
Type of material	Amount of light passing through material A
- D)

Variable X	Variable Y
Amount of light passing through material A	Type of material

Question Type: Multiple Choice
Randomize Answers: No
Date Added: Thu 5th Aug 2021
Last Modified: N/A
QID#: 28,628,087

[Answers](#) | [Edit](#) | [Duplicate](#) | [Used In](#) | [Reorder](#)

[Remove From Test](#)

Question 18

Primary 5 Science » Primary 5 Science (Term 2)

2 pts

Xu Long carried out an experiment on a seed growing into a seedling as shown below.

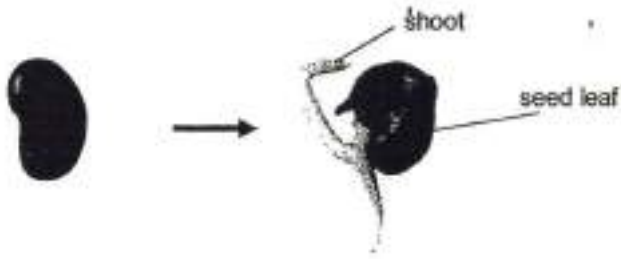

Which one of the following graphs correctly shows the changes in the mass of the seed leaf and the mass of the shoot of the seedling during the experiment?

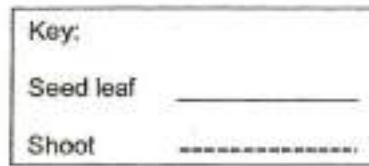

A)

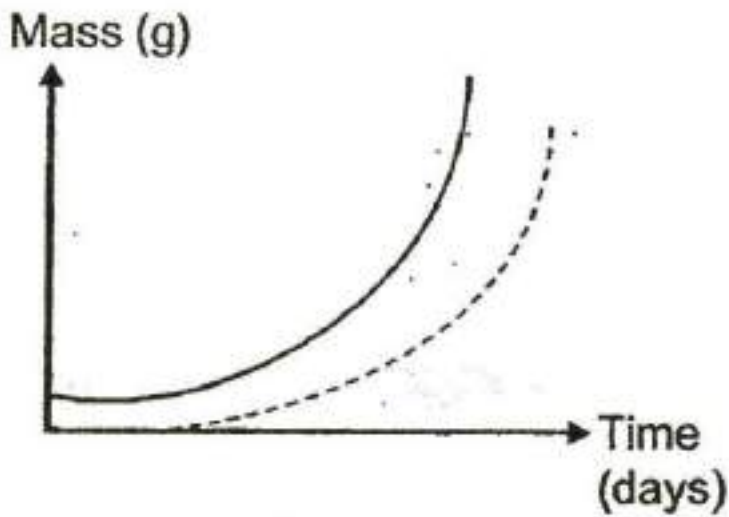

✓ B)

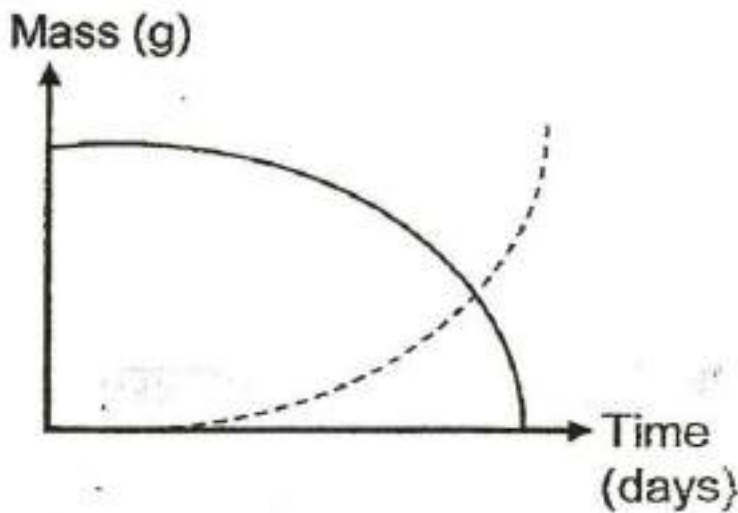

C)

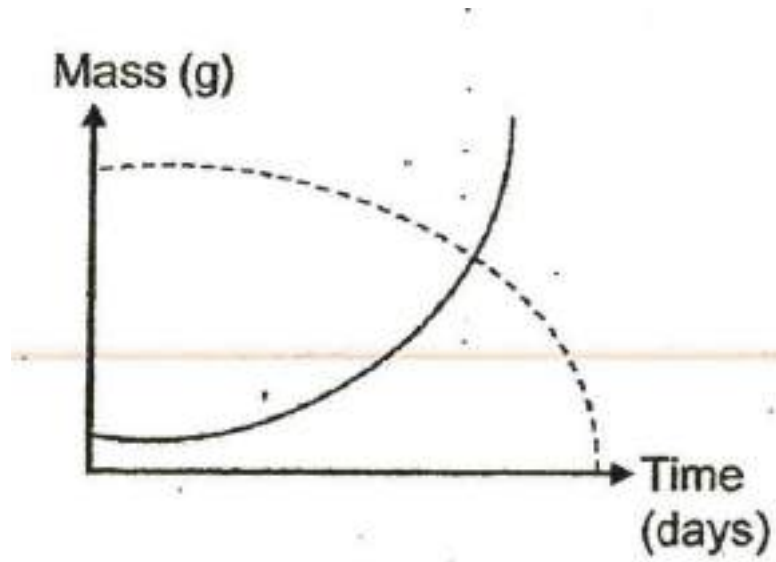

D)

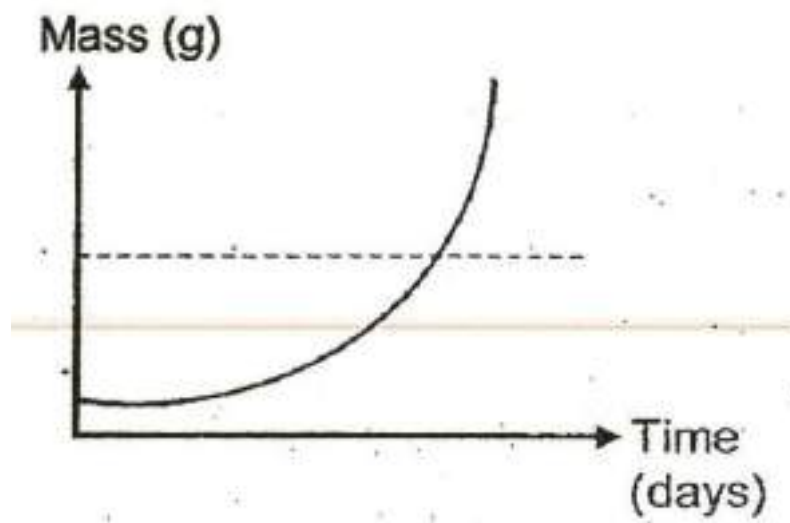

Question Type: Multiple Choice
Randomize Answers: No
Date Added: Thu 5th Aug 2021
Last Modified: N/A
QID#: 28,628,088

[Answers](#) | [Edit](#) | [Duplicate](#) | [Used In](#) | [Reorder](#)

[Remove From Test](#)

Question 19

Primary 5 Science » Primary 5 Science (Term 2)

2 pts

Titus cut out a square, a circle and a triangle from 3 sheets of material which are of the same size.

Front view

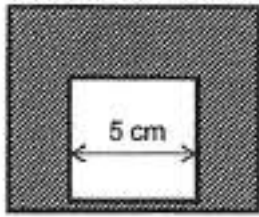

cardboard sheet



tissue sheet

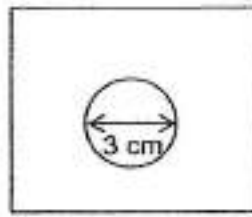

clear plastic sheet

Then he glued the 3 pieces of rectangular sheets with the cut-outs together and placed them, one in front of the other, between a torch and a screen in a dark room as shown below.

Side view

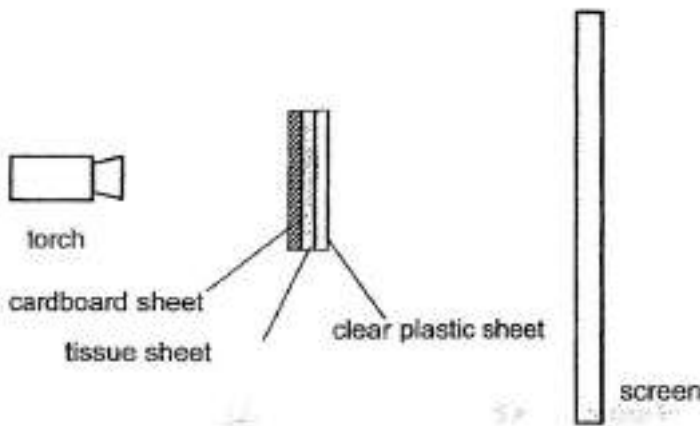

Which one of the following could be the shadow cast on the screen?

A)

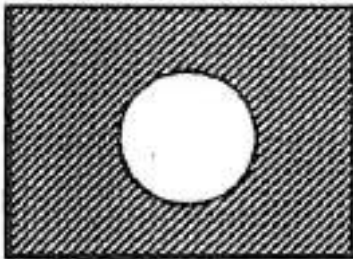

B)

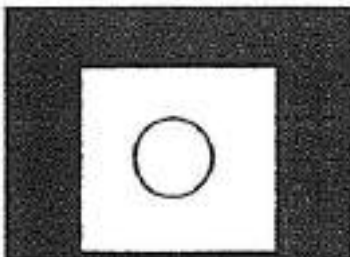

C)

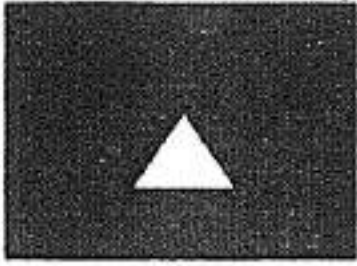

✓ D)

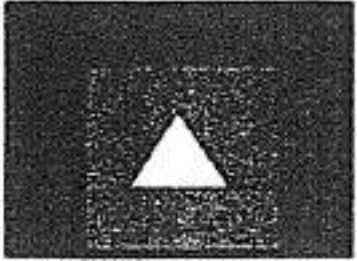

Question Type: Multiple Choice
Randomize Answers: No
Date Added: Thu 5th Aug 2021
Last Modified: N/A
QID#: 28,628,089

[Answers](#) | [Edit](#) | [Duplicate](#) | [Used In](#) | [Reorder](#)

[Remove From Test](#)

Question 20

Primary 5 Science » Primary 5 Science (Term 2)

2 pts

Mike carried out an experiment with Plant W which produced 2 different types of flower, A and B. The diagrams below show the parts of Flower A and Flower B.

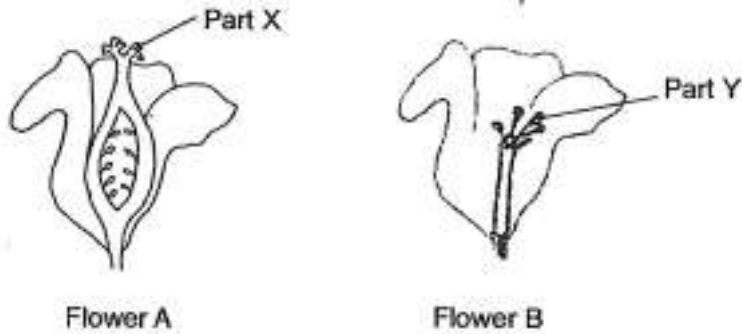

Mike rubbed Part Y of Flower B against Part X of Flower A. Then, he observed that there was some brown substance from Part Y that was left on Part X.

Which of the following statements are correct?

- P Flower A might develop into a fruit as pollination and fertilisation could have taken place.
 - Q Flower B might develop into a fruit as pollination and fertilisation could have taken place.
 - R Flower A will not develop into a fruit as it does not have male reproductive parts.
 - S Flower B will not develop into a fruit as it does not have female reproductive parts.
- A) P and Q only
- ✓ B) P and S only
- C) Q and R only
- D) R and S only

Question Type: Multiple Choice
Randomize Answers: No
Date Added: Thu 5th Aug 2021
Last Modified: N/A
QID#: 28,628,090

[Answers](#) | [Edit](#) | [Duplicate](#) | [Used In](#) | [Reorder](#)

[Remove From Test](#)

Question 21

Primary 5 Science » Primary 5 Science (Term 2)

2 pts

Two identical coins, F and G, were attached to the 2 similar rods of different materials by the same amount of wax as shown below.

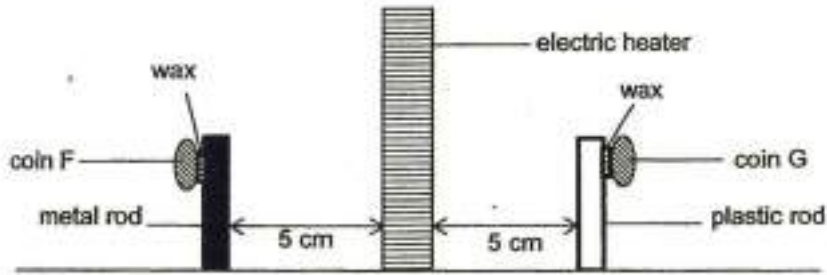

The electric heater was then switched on for 10 minutes.

Which of the following is the correct observation and its reason?

- A) Coin F will drop first as metal is a better conductor of heat.
- B) Coin F will drop first as metal can absorb more heat.
- C) Coin G will drop first as plastic is a better conductor of heat.
- D) Coin G will drop first as plastic surfaces can absorb more heat.

- ✓ A) A and B
- B) A and D
- C) B and C
- D) C and D

Question Type: Multiple Choice
 Randomize Answers: No
 Date Added: Thu 5th Aug 2021
 Last Modified: N/A
 QID#: 28,628,091

[Answers](#) | [Edit](#) | [Duplicate](#) | [Used In](#) | [Reorder](#)

[Remove From Test](#)

Question 22

Primary 5 Science » Primary 5 Science (Term 2)

2 pts

Fried ice cream is made by wrapping ice cream with a layer of bread dough. It is then fried in hot oil till the outer layer of dough is golden brown.

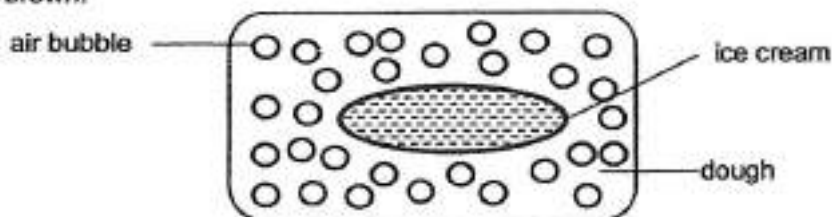

Which one of the following correctly explains why the ice cream does not melt during frying?

- A) Air is a good conductor of heat and conducts the heat away from the ice cream quickly.

- ✓ B) Air is a poor conductor of heat and slows down the heat gained by the ice cream.
- C) The ice cream is a good conductor of heat and conducts the heat away from it quickly.
- D) The ice cream is a poor conductor of heat and slows down the heat gained.

Question Type: Multiple Choice
Randomize Answers: No
Date Added: Thu 5th Aug 2021
Last Modified: N/A
QID#: 28,628,092

[Answers](#) |
 [Edit](#) |
 [Duplicate](#) |
 [Used In](#) |
 [Reorder](#)

[Remove From Test](#)

Question 23

Primary 5 Science » Primary 5 Science (Term 2)

2 pts

An inflated balloon was balanced by a wooden block on a balance as shown in the diagram below.

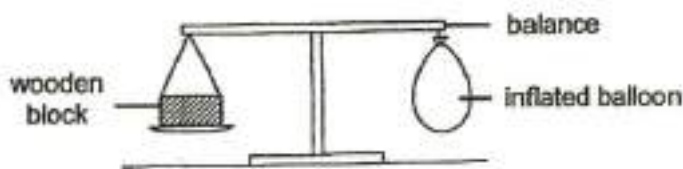

After some time, the air in the balloon escaped and the balloon became deflated.

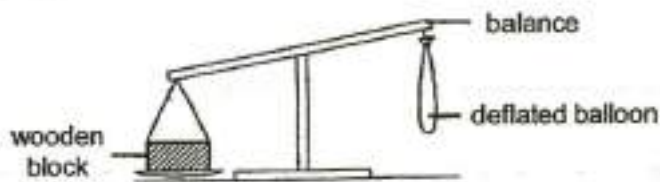

Which of the following statements correctly describe the observations shown above?

- W Air has mass.
 X Air occupies space.
 Y The inflated balloon has the same mass as the wooden block.
 Z The inflated balloon has the same volume as the wooden block.

- A) W and Z only
- B) X and Y only
- ✓ C) W, X and Y only
- D) W, X and Z only

Question Type: Multiple Choice
Randomize Answers: No
Date Added: Thu 5th Aug 2021
Last Modified: N/A
QID#: 28,628,093

[Answers](#) |
 [Edit](#) |
 [Duplicate](#) |
 [Used In](#) |
 [Reorder](#)

[Remove From Test](#)

Question 24

Primary 5 Science » Primary 5 Science (Term 2)

2 pts

Many fruits and seeds have special structures to help in their dispersal.

Which one of the following statements does **not** explain the importance of dispersal of seeds or fruits?

- ✓ A) It ensures extinction of the plants.
- B) It prevents overcrowding of the plants.
- C) It ensures that young plant will grow more healthily.
- D) It ensures that the plants will not compete with each other for basic needs.

Question Type: Multiple Choice
Randomize Answers: No
Date Added: Thu 5th Aug 2021
Last Modified: N/A
QID#: 28,628,094

[Answers](#) | [Edit](#) | [Duplicate](#) | [Used In](#) | [Reorder](#)

[Remove From Test](#)

Question 25

Primary 5 Science » Primary 5 Science (Term 2)

2 pts

Four different materials, A, B, C and D, were used to make ropes. The ropes were of the same length and thickness. Each rope was attached to a load.

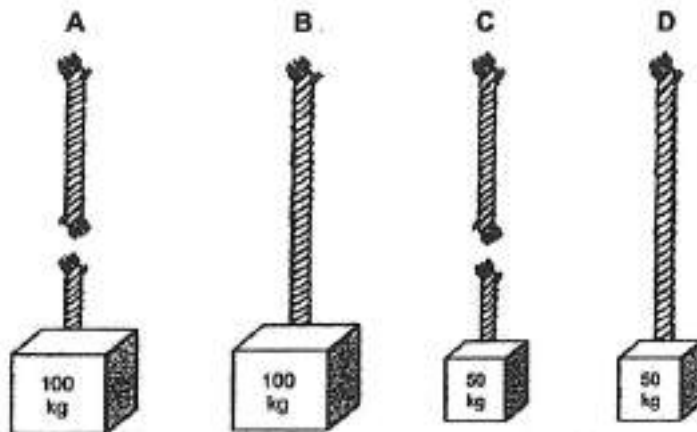

When each load was lifted, the ropes made of material A and material C snapped.

Based on the above observations only, which one of the following about materials A, B, C and D can be concluded?

- A) Material A is stronger than Material C.
- ✓ B) Material A is weaker than Material B.
- C) Material B is as strong as Material D.
- D) Material C is the weakest and Material B is the strongest.

Question Type: Multiple Choice
Randomize Answers: No
Date Added: Thu 5th Aug 2021
Last Modified: N/A
QID#: 28,628,095

[Answers](#) | [Edit](#) | [Duplicate](#) | [Used In](#) | [Reorder](#)

[Remove From Test](#)

Question 26

Primary 5 Science » Primary 5 Science (Term 2)

2 pts

The diagrams below show 2 fruits, R and S.

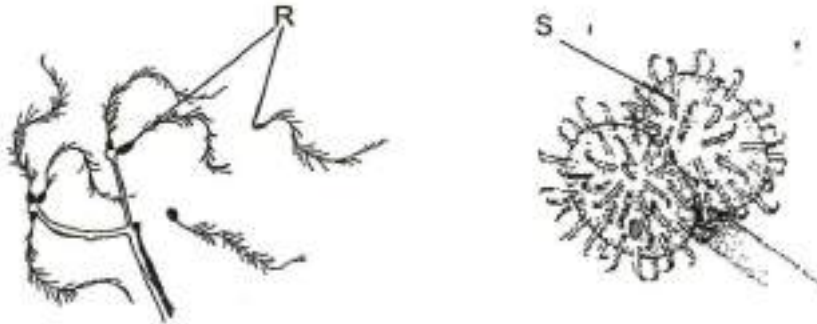

Based on the above diagrams, what are their methods of dispersal?

	Fruit	Method of dispersal
A	R	Water
B	R	Wind
C	S	Animals
D	S	Wind

- A) A and C only
 B) A and D only
 ✓ C) B and C only
 D) B and D only

Question Type: Multiple Choice
Randomize Answers: No
Date Added: Thu 5th Aug 2021
Last Modified: N/A
QID#: 28,628,096

[Answers](#) | [Edit](#) | [Duplicate](#) | [Used In](#) | [Reorder](#)

[Remove From Test](#)

Question 27

Primary 5 Science » Primary 5 Science (Term 2)

2 pts

Debbie suspended four magnets, P, Q, R and S from the same height above four trays of equal number of thumbtacks as shown in the diagram below.

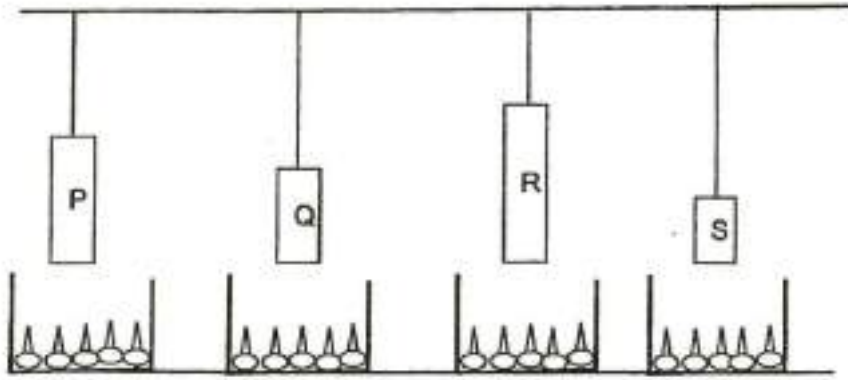

She observed the number of thumbtacks that each magnet was able to attract and recorded the results in the table below.

Magnet	P	Q	R	S
Number of thumbtacks attracted	5	3	7	9

Based on the above experiment, which of the following correctly explains the results in the table?

- A Magnetism can act from a distance.
- B Shorter magnets are weaker than longer magnets.
- C The strength of a magnet does not depend on its size.

- A) B only
- B) C only
- ✓ C) A and C
- D) A, B and C

Question Type: Multiple Choice
 Randomize Answers: No
 Date Added: Thu 5th Aug 2021
 Last Modified: N/A
 QID#: 28,628,097

[Answers](#) | [Edit](#) | [Duplicate](#) | [Used In](#) | [Reorder](#)





[Remove From Test](#)

Question 28

Primary 5 Science » Primary 5 Science (Term 2)

2 pts

The table below shows the method of dispersal of some fruits and seeds.

Method of dispersal	Fruits / Seeds
W	
X	
Y	
Z	

The diagram below shows the fruits and seeds of Plant F.

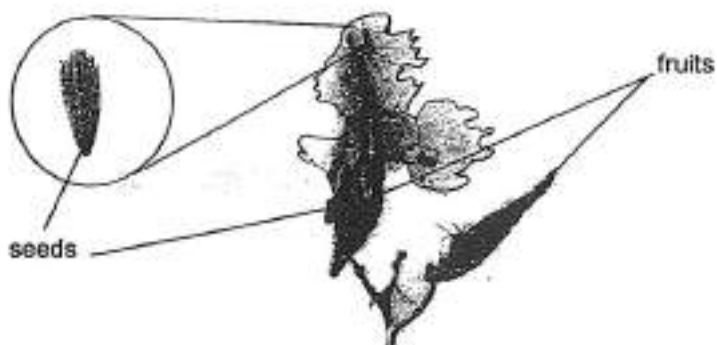

Based on the diagram above, which of the following are the methods of dispersal for Plant F?

- A) W and X only
- ✓ B) W and Y only
- C) X and Z only
- D) Y and Z only

Question Type: Multiple Choice
 Randomize Answers: No
 Date Added: Thu 5th Aug 2021
 Last Modified: N/A
 QID#: 28,628,098

[Answers](#) | [Edit](#) | [Duplicate](#) | [Used In](#) | [Reorder](#)

[Remove From Test](#)

Question 29

Primary 5 Science » Primary 5 Science (Term 2)

0 pts

One day, after a shower, Linda tied her wet hair into a bun as shown below.



Linda's mother suggested that she let her hair down so that it would dry faster.



Other than using a towel, suggest another method which Linda could use to dry her hair faster. (1 mark)

This question is designed for extended answers that parent/ teacher will have to assign and guide child to attempt after the test has been completed.

Grading: This question type is not graded on this system and will not affect the final score as it was designed in such a way that it requires manual assistance.

Question Type: Essay
Date Added: Thu 5th Aug 2021
Last Modified: N/A
QID#: 28,628,102

Correctly answered feedback

She could use a hair dryer.

Incorrectly answered feedback

She could use a hair dryer.

[Answers](#) | [Edit](#) | [Duplicate](#) | [Used In](#) | [Reorder](#)

[Remove From Test](#)

Question 30

Primary 5 Science » Primary 5 Science (Term 2)

0 pts

One day, after a shower, Linda tied her wet hair into a bun as shown below.



Linda's mother suggested that she let her hair down so that it would dry faster.



Explain why her mother's suggestion would help her hair dry faster. (1 mark)

This question is designed for extended answers that parent/ teacher will have to assign and guide child to attempt after the test has been completed.

Grading: This question type is not graded on this system and will not affect the final score as it was designed in such a way that it requires manual assistance.

Question Type: Essay
Date Added: Thu 5th Aug 2021
Last Modified: N/A
QID#: 28,628,125

Correctly answered feedback

When Linda let her hair down, it would have a larger exposed surface area and evaporation can take place faster.

Incorrectly answered feedback

When Linda let her hair down, it would have a larger exposed surface area and evaporation can take place faster.

[Answers](#) | [Edit](#) | [Duplicate](#) | [Used In](#) | [Reorder](#)

[Remove From Test](#)

Question 31

Primary 5 Science » Primary 5 Science (Term 2)

0 pts

Cheryl carried out an experiment as shown below.

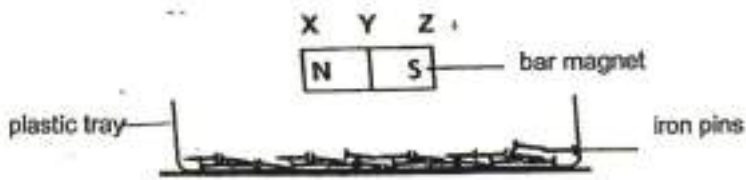

She filled a plastic tray with iron pins and lowered a bar magnet into it. Then she lifted the magnet and recorded the number of iron pins attracted to the different parts of the bar magnet. The table below shows the results of the experiment.

Parts of the bar magnet	No of iron pins attracted
Part X	8
Part Y	2
Part Z	9

What was the aim of her experiment? (1 mark)

This question is designed for extended answers that parent/ teacher will have to assign and guide child to attempt after the test has been completed.

Grading: This question type is not graded on this system and will not affect the final score as it was designed in such a way that it requires manual assistance.

Question Type: Essay
Date Added: Thu 5th Aug 2021
Last Modified: N/A
QID#: 28,628,103

Correctly answered feedback

To find out which part of the magnet is the strongest.

Incorrectly answered feedback

To find out which part of the magnet is the strongest.

[Answers](#) | [Edit](#) | [Duplicate](#) | [Used In](#) | [Reorder](#)

[Remove From Test](#)

Question 32

Primary 5 Science » Primary 5 Science (Term 2)

0 pts

Cheryl carried out an experiment as shown below.

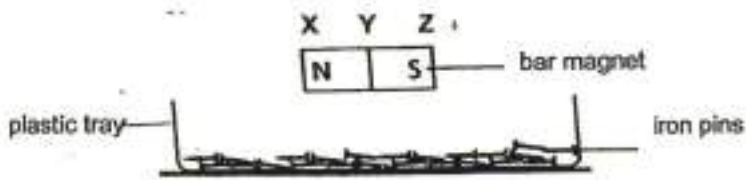

She filled a plastic tray with iron pins and lowered a bar magnet into it. Then she lifted the magnet and recorded the number of iron pins attracted to the different parts of the bar magnet. The table below shows the results of the experiment.

Parts of the bar magnet	No of iron pins attracted
Part X	8
Part Y	2
Part Z	9

Based on the above results, what can she conclude about the strength of the bar magnet? (1 mark)

This question is designed for extended answers that parent/ teacher will have to assign and guide child to attempt after the test has been completed.

Grading: This question type is not graded on this system and will not affect the final score as it was designed in such a way that it requires manual assistance.

Question Type: Essay
Date Added: Thu 5th Aug 2021
Last Modified: N/A
QID#: 28,628,104

Correctly answered feedback

Part X and Part Z of the magnet is the strongest part of the bar magnet.

Incorrectly answered feedback

Part X and Part Z of the magnet is the strongest part of the bar magnet.

[Answers](#) | [Edit](#) | [Duplicate](#) | [Used In](#) | [Reorder](#)

[Remove From Test](#)

Question 33

Primary 5 Science » Primary 5 Science (Term 2)

0 pts

Cheryl carried out an experiment as shown below.

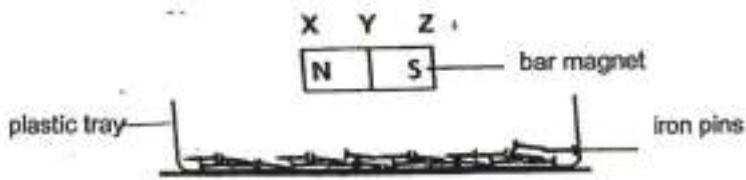

She filled a plastic tray with iron pins and lowered a bar magnet into it. Then she lifted the magnet and recorded the number of iron pins attracted to the different parts of the bar magnet. The table below shows the results of the experiment.

Parts of the bar magnet	No of iron pins attracted
Part X	8
Part Y	2
Part Z	9

What should Cheryl do in order to ensure reliable results? (1 mark)

This question is designed for extended answers that parent/ teacher will have to assign and guide child to attempt after the test has been completed.

Grading: This question type is not graded on this system and will not affect the final score as it was designed in such a way that it requires manual assistance.

Question Type: Essay
Date Added: Thu 5th Aug 2021
Last Modified: N/A
QID#: 28,628,106

Correctly answered feedback

She could repeat the experiment a few times.

Incorrectly answered feedback

She could repeat the experiment a few times.

[Answers](#) | [Edit](#) | [Duplicate](#) | [Used In](#) | [Reorder](#)

[Remove From Test](#)

Question 34

Primary 5 Science » Primary 5 Science (Term 2)

0 pts

Wayne carried out an experiment with 2 similar set-ups, A and B, as shown in diagram 1. Set-up A contains 50ml of chemical A and set-up B contains 50ml of water. Chemical A removes oxygen from the surroundings. Both set-ups were placed in the classroom.

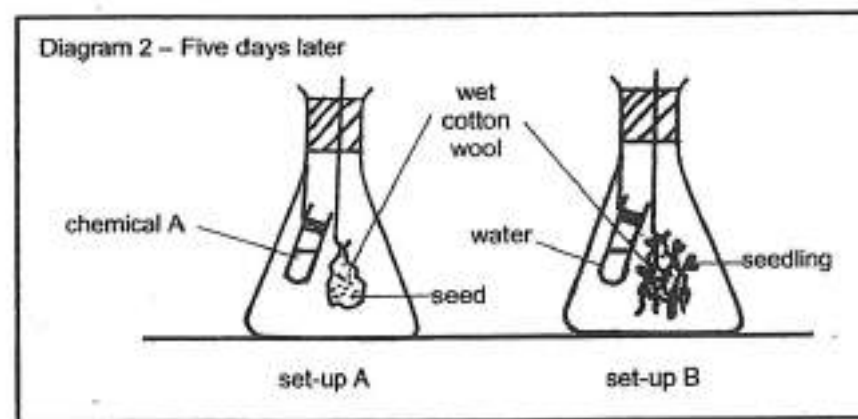
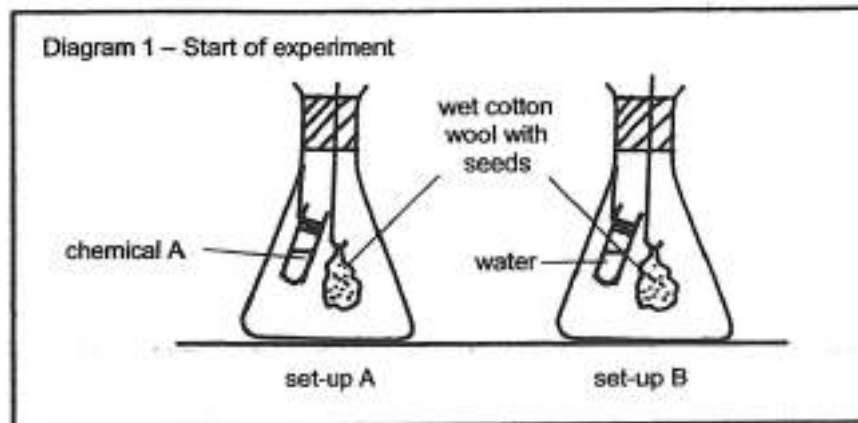

It was observed that the seeds in set-up A did not germinate. Give a reason for the observation. (1 mark)

This question is designed for extended answers that parent/ teacher will have to assign and guide child to attempt after the test has been completed.

Grading: This question type is not graded on this system and will not affect the final score as it was designed in such a way that it requires manual assistance.

Question Type: Essay
 Date Added: Thu 5th Aug 2021
 Last Modified: N/A
 QID#: 28,628,107

Correctly answered feedback

Air was not present, as the seed needs air to germinate.

Incorrectly answered feedback

Air was not present, as the seed needs air to germinate.

[Answers](#) | [Edit](#) | [Duplicate](#) | [Used In](#) | [Reorder](#)

[Remove From Test](#)

Question 35

Primary 5 Science » Primary 5 Science (Term 2)

0 pts

Wayne carried out an experiment with 2 similar set-ups, A and B, as shown in diagram 1. Set-up A contains 50ml of chemical A and set-up B contains 50ml of water. Chemical A removes oxygen from the surroundings. Both set-ups were placed in the classroom.

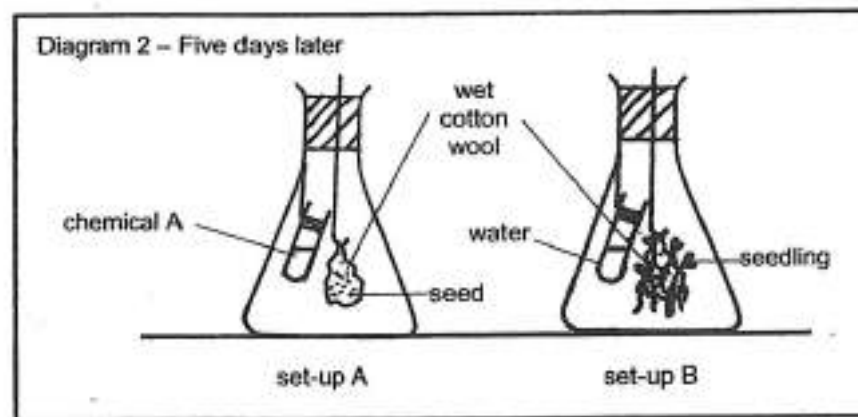
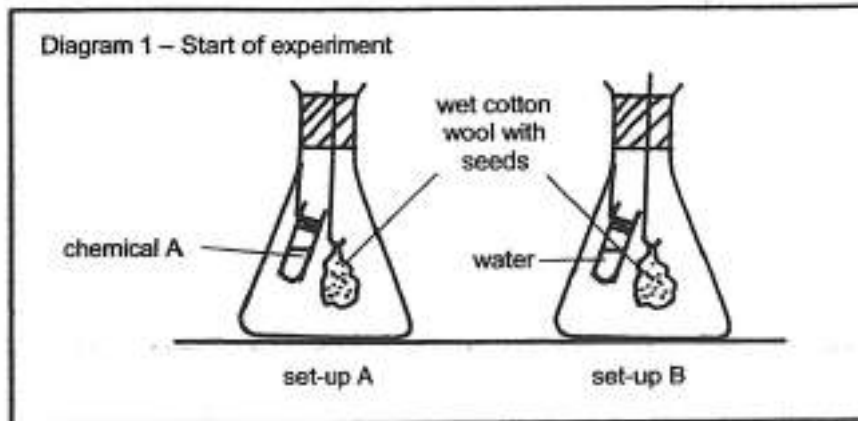

Wayne then replaced chemical A in Set-up A with 50ml of water and the water in set-up B with chemical A as shown in diagram 3 below.

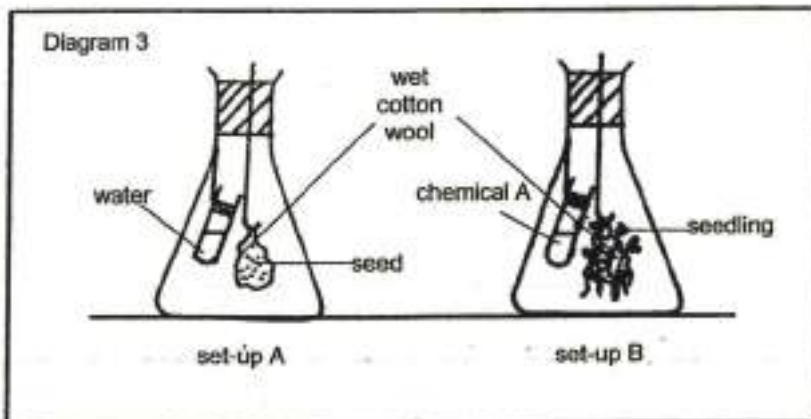

He left the above set-ups in the classroom for another 5 days.

What will he most likely observe in each of the set-ups in diagram 3 after 5 days? [1]

Set-up A: _____

Set-up B: _____

This question is designed for extended answers that parent/ teacher will have to assign and guide child

to attempt after the test has been completed.

Grading: This question type is not graded on this system and will not affect the final score as it was designed in such a way that it requires manual assistance.

Question Type: Essay
Date Added: Thu 5th Aug 2021
Last Modified: N/A
QID#: 28,628,109

Correctly answered feedback

Set-up A: Starts to germinate.

Set-up B: The seedlings would die.

Incorrectly answered feedback

Set-up A: Starts to germinate.

Set-up B: The seedlings would die.

[Answers](#) | [Edit](#) | [Duplicate](#) | [Used In](#) | [Reorder](#)

[Remove From Test](#)

Question 36

Primary 5 Science » Primary 5 Science (Term 2)

0 pts

Irfan fried two pineapple pies and placed them into boxes A and B as shown in the diagrams below.



Box A



Box B

After some time, Irfan observed that the pineapple pie in box A became slightly wet compared to that in box B.

Explain clearly how the holes in box B helped to keep the pineapple pie dry and crispy. [2]

This question is designed for extended answers that parent/ teacher will have to assign and guide child to attempt after the test has been completed.

Grading: This question type is not graded on this system and will not affect the final score as it was designed in such a way that it requires manual assistance.

Question Type: Essay
Date Added: Thu 5th Aug 2021
Last Modified: N/A
QID#: 28,628,108

Correctly answered feedback

The 2 holes allow more water vapour to escape from the packaging thus reduces amount water vapour that would condense into water droplets.

Incorrectly answered feedback

The 2 holes allow more water vapour to escape from the packaging thus reduces amount water vapour that would condense into water droplets.

[Answers](#) | [Edit](#) | [Duplicate](#) | [Used In](#) | [Reorder](#)

[Remove From Test](#)

Question 37

Primary 5 Science » Primary 5 Science (Term 2)

0 pts

Niki wanted to investigate if the size of flowers affects the number of bees that landed on them. She made flowers of 3 different sizes using the same type of yellow paper as shown in diagram below. In the centre of each flower, she attached a ball of cotton wool containing nectar from the same flower.



She placed the 3 flowers in the garden and counted the number of bees that landed on each flower over 4 hours.

Is Niki's experiment a fair test? Explain your answer. (1 mark)

This question is designed for extended answers that parent/ teacher will have to assign and guide child to attempt after the test has been completed.

Grading: This question type is not graded on this system and will not affect the final score as it was designed in such a way that it requires manual assistance.

Question Type: Essay
Date Added: Thu 5th Aug 2021
Last Modified: N/A
QID#: 28,628,111

Correctly answered feedback

Yes. All other variables are the same and there is only one changed variable which is the size of the flowers.

Incorrectly answered feedback

Yes. All other variables are the same and there is only one changed variable which is the size of the flowers.

[Answers](#) | [Edit](#) | [Duplicate](#) | [Used In](#) | [Reorder](#)

[Remove From Test](#)

Question 38

Primary 5 Science » Primary 5 Science (Term 2)

0 pts

Niki wanted to investigate if the size of flowers affects the number of bees that landed on them. She made flowers of 3 different sizes using the same type of yellow paper as shown in diagram below. In the centre of each flower, she attached a ball of cotton wool containing nectar from the same flower.



She placed the 3 flowers in the garden and counted the number of bees that landed on each flower over 4 hours.

Niki recorded her observations in the table below.



Length L (cm)	Number of bees that landed on the flowers
5	9
10	17
15	46

Give a reason why her results were not reliable. (1 mark)

This question is designed for extended answers that parent/ teacher will have to assign and guide child to attempt after the test has been completed.

Grading: This question type is not graded on this system and will not affect the final score as it was designed in such a way that it requires manual assistance.

Question Type: Essay
 Date Added: Thu 5th Aug 2021
 Last Modified: N/A
 QID#: 28,628,114

Correctly answered feedback

She only did the experiment once.

Incorrectly answered feedback

She only did the experiment once.

[Answers](#) | [Edit](#) | [Duplicate](#) | [Used In](#) | [Reorder](#)

[Remove From Test](#)

Question 39

Primary 5 Science » Primary 5 Science (Term 2)

0 pts

Niki wanted to investigate if the size of flowers affects the number of bees that landed on them. She made flowers of 3 different sizes using the same type of yellow paper as shown in diagram below. In the centre of each flower, she attached a ball of cotton wool containing nectar from the same flower.



She placed the 3 flowers in the garden and counted the number of bees that landed on each flower over 4 hours.

Niki recorded her observations in the table below.



Length L (cm)	Number of bees that landed on the flowers
5	9
10	17
15	46

Based on the results recorded in the table above, what is the relationship between the size of the flowers and the number of bees that landed on them?
(1 mark)

This question is designed for extended answers that parent/ teacher will have to assign and guide child to attempt after the test has been completed.

Grading: This question type is not graded on this system and will not affect the final score as it was designed in such a way that it requires manual assistance.

Question Type: Essay
Date Added: Thu 5th Aug 2021
Last Modified: N/A
QID#: 28,628,113

Correctly answered feedback

The longer the Length L, the more number of bees that landed on the flowers.

Incorrectly answered feedback

The longer the Length L, the more number of bees that landed on the flowers.

[Answers](#) | [Edit](#) | [Duplicate](#) | [Used In](#) | [Reorder](#)

[Remove From Test](#)

Question 40

Primary 5 Science » Primary 5 Science (Term 2)

0 pts

Cheryl used the same bar magnet to stroke nail A 50 times. Then, it was observed that it could pick up nail B.

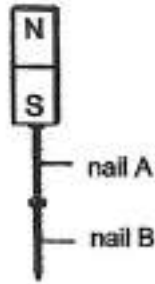

Cheryl then used the same bar magnet to stroke nail B. When she brought nail A close to nail B again, she noticed that nail B moved away.

Give a reason for her observations. (1 mark)

This question is designed for extended answers that parent/ teacher will have to assign and guide child to attempt after the test has been completed.

Grading: This question type is not graded on this system and will not affect the final score as it was designed in such a way that it requires manual assistance.

Question Type: Essay
Date Added: Thu 5th Aug 2021
Last Modified: N/A
QID#: 28,628,112

Correctly answered feedback

Both the nails had become temporary magnet and like poles facing each other repel.

Incorrectly answered feedback

Both the nails had become temporary magnet and like poles facing each other repel.

[Answers](#) | [Edit](#) | [Duplicate](#) | [Used In](#) | [Reorder](#)

[Remove From Test](#)

Question 41

Primary 5 Science » Primary 5 Science (Term 2)

0 pts

Cheryl used the same bar magnet to stroke nail A 50 times. Then, it was observed that it could pick up nail B.

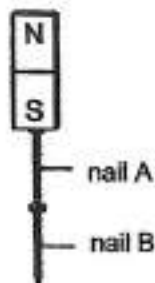

Give a reason why nail A could attract nail B. (1 mark)

This question is designed for extended answers that parent/ teacher will have to assign and guide child to attempt after the test has been completed.

Grading: This question type is not graded on this system and will not affect the final score as it was designed in such a way that it requires manual assistance.

Question Type: Essay
Date Added: Thu 5th Aug 2021
Last Modified: N/A
QID#: 28,628,110

Correctly answered feedback

Nail A had become a temporary magnet, nail B is made of magnetic material thus nail A could attract nail B.

Incorrectly answered feedback

Nail A had become a temporary magnet, nail B is made of magnetic material thus nail A could attract nail B.

[Answers](#) | [Edit](#) | [Duplicate](#) | [Used In](#) | [Reorder](#)

[Remove From Test](#)

Question 42

Primary 5 Science » Primary 5 Science (Term 2)

0 pts

- May used 3 different types of material, S, T and U, of the same thickness for her experiment. She positioned material S in a wooden box as shown in the set-up below and recorded the amount of light detected by the light sensor.

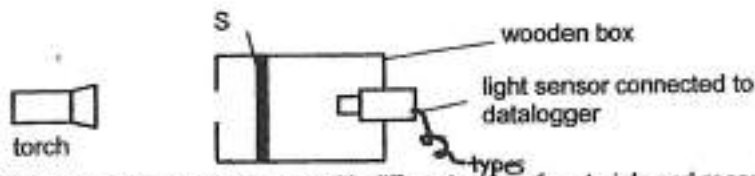

She repeated the experiment with different types of materials and recorded the amount of light detected by the light sensor in the table below.

Set-up	Materials placed in the box	Amount of light detected (units)
1	S	250
2	T	150
3	U	50

Based on the experiment above, state one variable that May had to keep constant for it to be a fair test. (1 mark)

This question is designed for extended answers that parent/ teacher will have to assign and guide child to attempt after the test has been completed.

Grading: This question type is not graded on this system and will not affect the final score as it was designed in such a way that it requires manual assistance.

Question Type: Essay
Date Added: Thu 5th Aug 2021
Last Modified: N/A
QID#: 28,628,116

Correctly answered feedback

The amount of light given by the torch.

Incorrectly answered feedback

The amount of light given by the torch.

[Answers](#) | [Edit](#) | [Duplicate](#) | [Used In](#) | [Reorder](#)

[Remove From Test](#)

Question 43

Primary 5 Science » Primary 5 Science (Term 2)

0 pts

- May used 3 different types of material, S, T and U, of the same thickness for her experiment. She positioned material S in a wooden box as shown in the set-up below and recorded the amount of light detected by the light sensor.

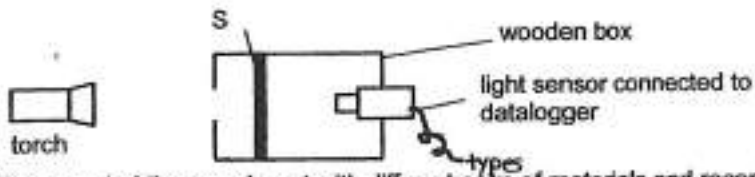

She repeated the experiment with different types of materials and recorded the amount of light detected by the light sensor in the table below.

Set-up	Materials placed in the box	Amount of light detected (units)
1	S	250
2	T	150
3	U	50

Using the same set-up and materials, suggest one way to increase the amount of light detected by the light sensor. (1 mark)

This question is designed for extended answers that parent/ teacher will have to assign and guide child to attempt after the test has been completed.

Grading: This question type is not graded on this system and will not affect the final score as it was designed in such a way that it requires manual assistance.

Question Type: Essay
 Date Added: Thu 5th Aug 2021
 Last Modified: N/A
 QID#: 28,628,117

Correctly answered feedback

Increase the intensity of the light.

Incorrectly answered feedback

Increase the intensity of the light.

[Answers](#) | [Edit](#) | [Duplicate](#) | [Used In](#) | [Reorder](#)

[Remove From Test](#)

Question 44

Primary 5 Science » Primary 5 Science (Term 2)

1 pt

May wanted to use one of the materials from her experiment to make the rooftop windows of her house so that she would not need to switch on the lights during the day.

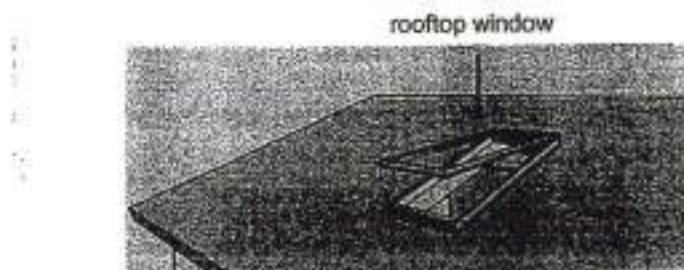

Which material, S, T or U, is the most suitable for making the rooftop window? Give a reason for your answer. [1]

Accepted answers:

- ✓ Material S
- ✓ S

Question Type: Free Text
Date Added: Thu 5th Aug 2021
Last Modified: N/A
QID#: 28,628,133

Correctly answered feedback

Material S. It allowed the most light to pass through.

Incorrectly answered feedback

Material S. It allowed the most light to pass through.

[Answers](#) |
 [Edit](#) |
 [Duplicate](#) |
 [Used In](#) |
 [Reorder](#)

[Remove From Test](#)

Question 45

Primary 5 Science » Primary 5 Science (Term 2)

0 pts

Winnie set up the experiment as shown below.

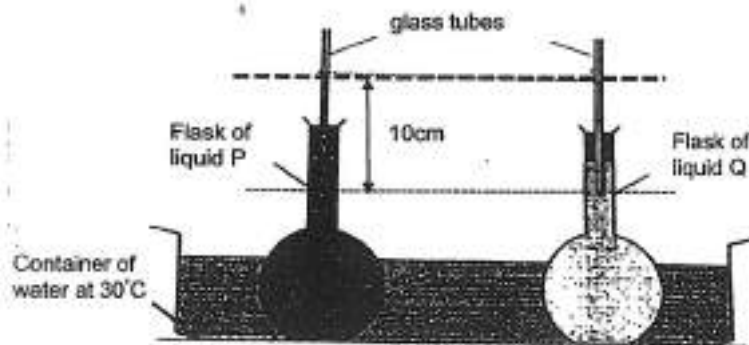

Winnie made sure that when both flasks were immersed in the container of water at 30 °C, the levels of liquids P and Q in the glass tube were the same. Liquid P is a better conductor of heat than liquid Q.

Winnie observed the levels of liquid in both flasks when she added a bucket of ice cubes into the container of water and recorded her results in the table below.

Time (min)	Level of liquid P (cm)	Level of liquid Q (cm)
0	10	10
2	8	9
4	5	7
6	2	5

Based on the table above, explain the results of her experiment. (1 mark)

This question is designed for extended answers that parent/ teacher will have to assign and guide child to attempt after the test has been completed.

Grading: This question type is not graded on this system and will not affect the final score as it was designed in such a way that it requires manual assistance.

Question Type: Essay
Date Added: Thu 5th Aug 2021

Last Modified: N/A
QID#: 28,628,118

Correctly answered feedback

Level in Liquid P decreased faster than in Liquid Q as the volume of Liquid P decreased at a faster rate.

Incorrectly answered feedback

Level in Liquid P decreased faster than in Liquid Q as the volume of Liquid P decreased at a faster rate.

[Answers](#) | [Edit](#) | [Duplicate](#) | [Used In](#) | [Reorder](#)

[Remove From Test](#)

Question 46

Primary 5 Science » Primary 5 Science (Term 2)

0 pts

Winnie set up the experiment as shown below.

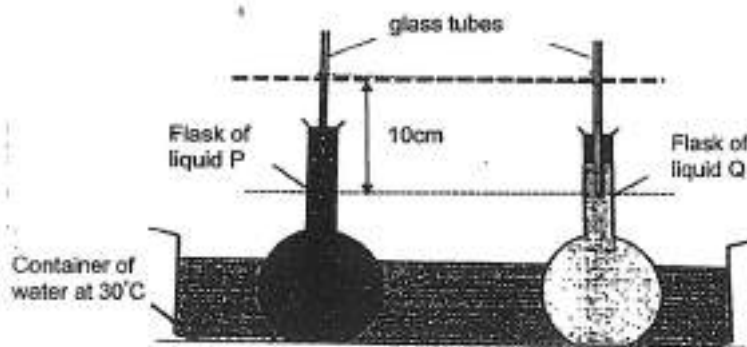

Winnie made sure that when both flasks were immersed in the container of water at 30 °C, the levels of liquids P and Q in the glass tube were the same. Liquid P is a better conductor of heat than liquid Q.

Winnie observed the levels of liquid in both flasks when she added a bucket of ice cubes into the container of water and recorded her results in the table below.

Time (min)	Level of liquid P (cm)	Level of liquid Q (cm)
0	10	10
2	8	9
4	5	7
6	2	5

Explain your answer in the previous question. (2 marks)

This question is designed for extended answers that parent/ teacher will have to assign and guide child to attempt after the test has been completed.

Grading: This question type is not graded on this system and will not affect the final score as it was designed in such a way that it requires manual assistance.

Question Type: Essay
Date Added: Thu 5th Aug 2021
Last Modified: N/A
QID#: 28,628,119

Correctly answered feedback

Liquid P contracted more quickly thus the volume of Liquid P decreases faster.

Incorrectly answered feedback

Liquid P contracted more quickly thus the volume of Liquid P decreases faster.

[Answers](#) |
 [Edit](#) |
 [Duplicate](#) |
 [Used In](#) |
 [Reorder](#)

[Remove From Test](#)

Question 47

Primary 5 Science » Primary 5 Science (Term 2)

0 pts

Winnie discovered that houses in cold countries have windows that have two layers of glass, trapping a layer of air between them, as shown in the diagram below.

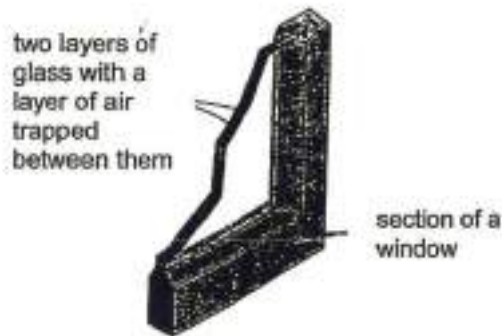

Explain how windows with two layers of glass help to keep the temperature inside the room higher than the temperature outside the house for a longer period of time. [1]

This question is designed for extended answers that parent/ teacher will have to assign and guide child to attempt after the test has been completed.

Grading: This question type is not graded on this system and will not affect the final score as it was designed in such a way that it requires manual assistance.

Question Type: Essay
Date Added: Thu 5th Aug 2021
Last Modified: N/A
QID#: 28,628,120

Correctly answered feedback

Air is a poor conductor of heat. It slows down the heat lost from the inside of the house to the outside of the house.

Incorrectly answered feedback

Air is a poor conductor of heat. It slows down the heat lost from the inside of the house to the outside of the house.

[Answers](#) |
 [Edit](#) |
 [Duplicate](#) |
 [Used In](#) |
 [Reorder](#)

[Remove From Test](#)

Question 48

Primary 5 Science » Primary 5 Science (Term 2)

0 pts

Farah wanted to take back the following objects which she had dropped into a deep and narrow hole in the ground but her arms could not reach them.

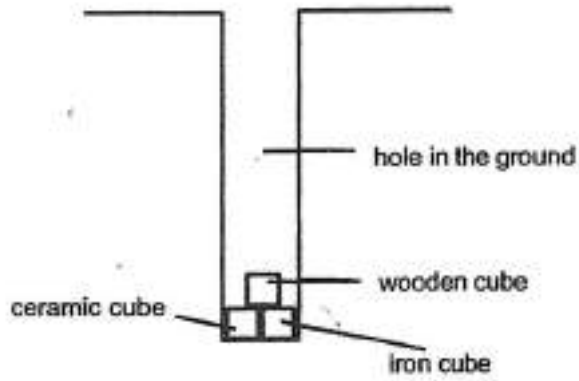

Farah had a ball of cotton string, a pail of water and a bar magnet.

With the above items, which of the object(s) would she be able to take out from the hole in the ground? (1 mark)

This question is designed for extended answers that parent/ teacher will have to assign and guide child to attempt after the test has been completed.

Grading: This question type is not graded on this system and will not affect the final score as it was designed in such a way that it requires manual assistance.

Question Type: Essay
Date Added: Thu 5th Aug 2021
Last Modified: N/A
QID#: 28,628,122

Correctly answered feedback

She would take out the iron and the wooden cube.

Incorrectly answered feedback

She would take out the iron and the wooden cube.

[Answers](#) | [Edit](#) | [Duplicate](#) | [Used In](#) | [Reorder](#)

[Remove From Test](#)

Question 49

Primary 5 Science » Primary 5 Science (Term 2)

0 pts

Farah wanted to take back the following objects which she had dropped into a deep and narrow hole in the ground but her arms could not reach them.

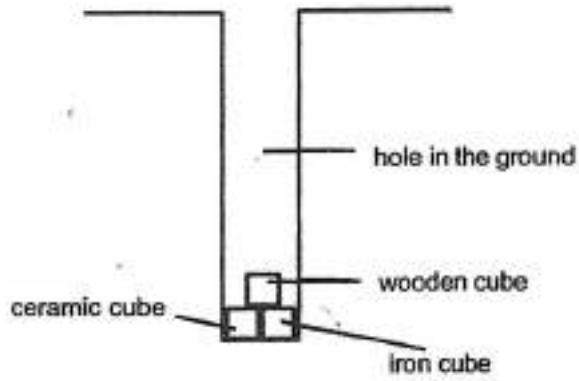

Farah had a ball of cotton string, a pail of water and a bar magnet.

Describe and explain how she could take out the object(s) you had stated in the previous question. (2 marks)

This question is designed for extended answers that parent/ teacher will have to assign and guide child to attempt after the test has been completed.

Grading: This question type is not graded on this system and will not affect the final score as it was designed in such a way that it requires manual assistance.

Question Type: Essay
Date Added: Thu 5th Aug 2021
Last Modified: N/A
QID#: 28,628,126

Correctly answered feedback

She could use a magnet to attract the iron cube as it is a magnetic material.

She could pour water into the hold in the ground and the wooden cube will float as it is less dense than the water.

Incorrectly answered feedback

She could use a magnet to attract the iron cube as it is a magnetic material.

She could pour water into the hold in the ground and the wooden cube will float as it is less dense than the water.

[Answers](#) | [Edit](#) | [Duplicate](#) | [Used In](#) | [Reorder](#)

[Remove From Test](#)

Question 50

Primary 5 Science » Primary 5 Science (Term 2)

0 pts

Linda conducted an experiment to find out how the temperature of a liquid affects the time taken for it to evaporate. She poured 100ml of the liquid into four identical beakers, A, B, C and D. She then heated the liquid in each beaker to different temperatures as shown in the table below. She placed the beakers in a room and recorded the time taken for the liquid in each beaker to evaporate completely in the table below.

Beaker	Temperature of liquid at the start of experiment (°C)	Time taken (h)
A	30	8
B	50	5
C	70	3
D	90	2

Based on the results above, what can Linda conclude from her experiment?
(1 mark)

This question is designed for extended answers that parent/ teacher will have to assign and guide child to attempt after the test has been completed.

Grading: This question type is not graded on this system and will not affect the final score as it was designed in such a way that it requires manual assistance.

Question Type: Essay
Date Added: Thu 5th Aug 2021
Last Modified: N/A
QID#: 28,628,123

Correctly answered feedback

She would conclude that the lower the temperature, the slower it evaporates.

Incorrectly answered feedback

She would conclude that the lower the temperature, the slower it evaporates.

[Answers](#) | [Edit](#) | [Duplicate](#) | [Used In](#) | [Reorder](#)

[Remove From Test](#)

Question 51

Primary 5 Science » Primary 5 Science (Term 2)

0 pts

Linda conducted an experiment to find out how the temperature of a liquid affects the time taken for it to evaporate. She poured 100ml of the liquid into four identical beakers, A, B, C and D. She then heated the liquid in each beaker to different temperatures as shown in the table below. She placed the beakers in a room and recorded the time taken for the liquid in each beaker to evaporate completely in the table below.

Beaker	Temperature of liquid at the start of experiment (°C)	Time taken (h)
A	30	8
B	50	5
C	70	3
D	90	2

Explain clearly why it is not a fair test if Linda had used 4 beakers of different sizes for her experiment.
(2 marks)

This question is designed for extended answers that parent/ teacher will have to assign and guide child to attempt after the test has been completed.

Grading: This question type is not graded on this system and will not affect the final score as it was designed in such a way that it requires manual assistance.

Question Type: Essay
Date Added: Thu 5th Aug 2021
Last Modified: N/A
QID#: 28,628,124

Correctly answered feedback

There would be larger exposed surface so the rate of evaporation will be faster thus the hair will dry faster.

Incorrectly answered feedback

There would be larger exposed surface so the rate of evaporation will be faster thus the hair will dry faster.

Answers | Edit | Duplicate | Used In | Reorder

Remove From Test

Question 52

Primary 5 Science » Primary 5 Science (Term 2)

1 pt

The diagrams below show the reproductive systems of human and plant.

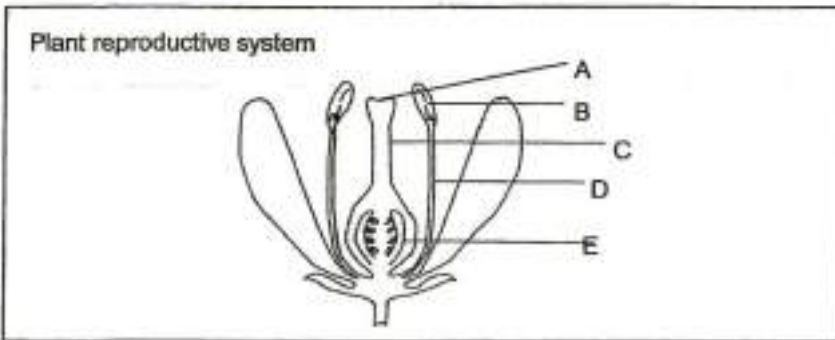
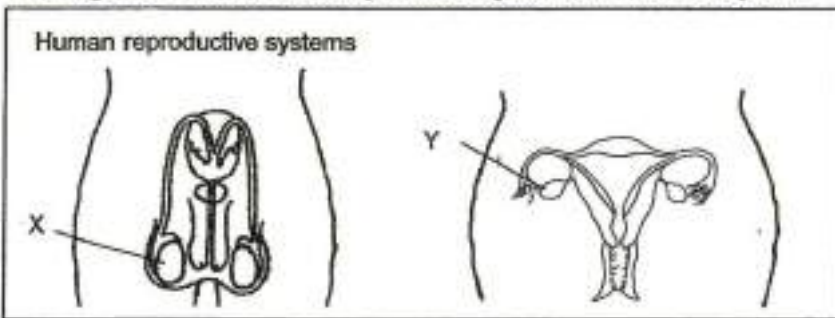

The table below compares the reproductive parts of the human and the equivalent part in the flower.

Fill in the reproductive parts (i) in the table below with A, B, C, D or E.

	Human	Plants
Male reproductive parts	X	(i)
Function	contains sperms	(ii)
Female reproductive parts	Y	(iii)
Function	contain eggs	(iv)

Accepted answers:

✓ B

Question Type: Free Text
 Date Added: Thu 5th Aug 2021
 Last Modified: N/A
 QID#: 28,628,139

[Answers](#) |
 [Edit](#) |
 [Duplicate](#) |
 [Used In](#) |
 [Reorder](#)

[Remove From Test](#)

Question 53

Primary 5 Science » Primary 5 Science (Term 2)

0 pts

The diagrams below show the reproductive systems of human and plant.

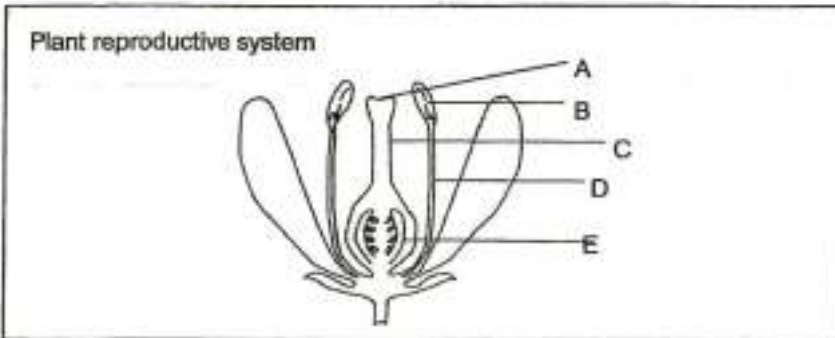
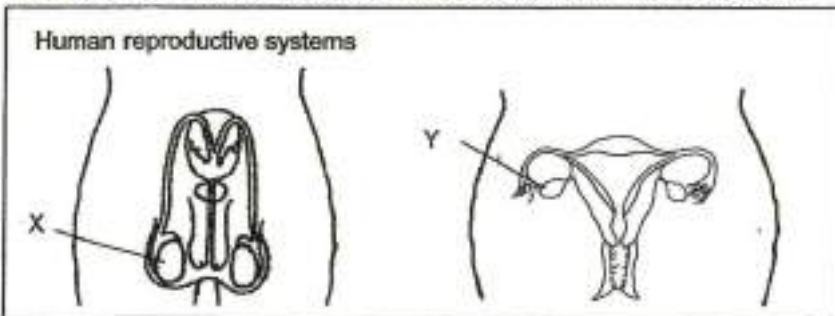

The table below compares the reproductive parts of the human and the equivalent part in the flower.

	Human	Plants
Male reproductive parts	X	(i)
Function	contains sperms	(ii)
Female reproductive parts	Y	(iii)
Function	contain eggs	(iv)

Complete the table above by filling in the functions (ii) and (iv). (2 marks)

This question is designed for extended answers that parent/ teacher will have to assign and guide child to attempt after the test has been completed.

Grading: This question type is not graded on this system and will not affect the final score as it was designed in such a way that it requires manual assistance.

Question Type: Essay
Date Added: Thu 5th Aug 2021
Last Modified: N/A
QID#: 28,628,105

Correctly answered feedback

- (ii) Contains pollen grains
- (iv) Contains ovules

Incorrectly answered feedback

- (ii) Contains pollen grains
- (iv) Contains ovules

[Answers](#) |
 [Edit](#) |
 [Duplicate](#) |
 [Used In](#) |
 [Reorder](#)

[Remove From Test](#)

Question 54

Primary 5 Science » Primary 5 Science (Term 2)

1 pt

The diagrams below show the reproductive systems of human and plant.

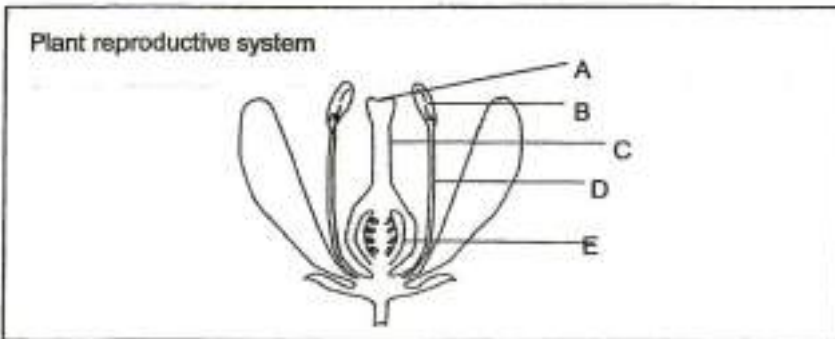
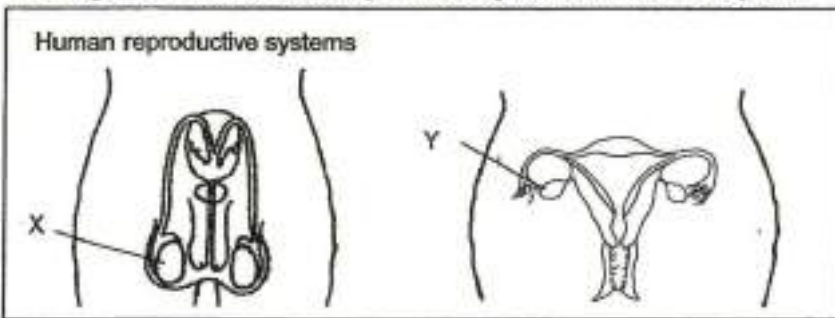

The table below compares the reproductive parts of the human and the equivalent part in the flower.

Fill in the reproductive parts (iii) in the table below with A, B, C, D or E.

	Human	Plants
Male reproductive parts	X	(i)
Function	contains sperms	(ii)
Female reproductive parts	Y	(iii)
Function	contain eggs	(iv)

Accepted answers:

✓ E

Question Type: Free Text
Date Added: Thu 5th Aug 2021
Last Modified: N/A
QID#: 28,628,127

[Answers](#) |
 [Edit](#) |
 [Duplicate](#) |
 [Used In](#) |
 [Reorder](#)

[Remove From Test](#)

Question 55

Primary 5 Science » Primary 5 Science (Term 2)

2 pts

Irfan poured 400ml of water at 50°C into a beaker in each of the 3 set-ups, S, T and U, as shown in the diagram below. He covered each beaker with a plastic lid and placed a different number of ice cubes on the plastic lids.

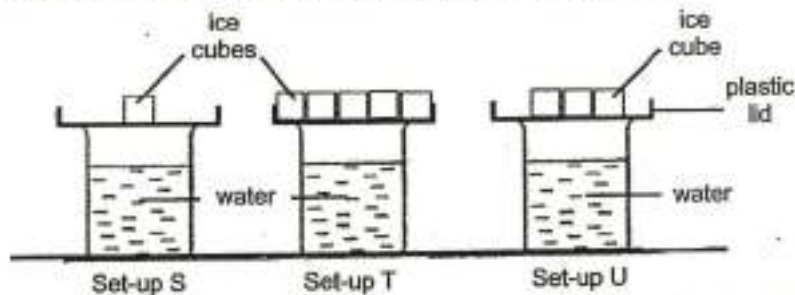

He then observed the amount of water droplets formed on the underside of the plastic lid after 1 minute.

Which set-up would have the most number of water droplets? Explain your answer.

Accepted answers:

- ✓ Set-up T.
- ✓ Set - Up T
- ✓ Set-Up T
- ✓ setup T

Question Type: Free Text
Date Added: Thu 5th Aug 2021
Last Modified: N/A
QID#: 28,628,128

Correctly answered feedback

Setup T. It allowed condensation to occur quicker as it had the most number of ice cubes.

Incorrectly answered feedback

Setup T. It allowed condensation to occur quicker as it had the most number of ice cubes.

[Answers](#) |
 [Edit](#) |
 [Duplicate](#) |
 [Used In](#) |
 [Reorder](#)

[Remove From Test](#)

Question 56

Primary 5 Science » Primary 5 Science (Term 2)

1 pt

Zhiming put the same number of ice cubes into two plastic bags, A and B. The plastic bags were then placed into another air-tight bag as shown in the diagram below.

The air in the air-tight bag in set-up A was removed before sealing. He then left both bags in a room of 28°C.

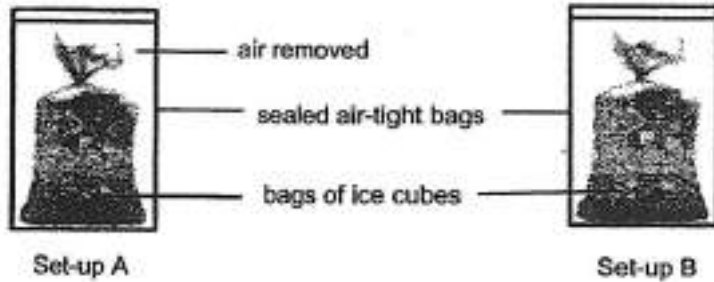

After 30 minutes, Zhiming observed a mixture of water and ice cubes in the two plastic bags.

State the process that had taken in the two plastic bags.

Accepted answers:

- ✓ Melting
- ✓ Melting process

Question Type: Free Text
 Date Added: Thu 5th Aug 2021
 Last Modified: N/A
 QID#: 28,628,129

[Answers](#) | [Edit](#) | [Duplicate](#) | [Used In](#) | [Reorder](#)

[Remove From Test](#)

Question 57

Primary 5 Science » Primary 5 Science (Term 2)

1 pt

Zhiming put the same number of ice cubes into two plastic bags, A and B. The plastic bags were then placed into another air-tight bag as shown in the diagram below.

The air in the air-tight bag in set-up A was removed before sealing. He then left both bags in a room of 28°C.

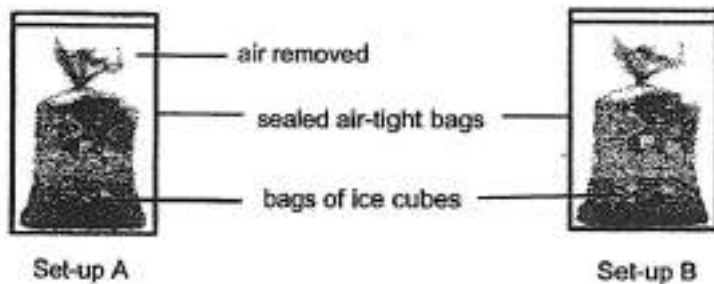

After 30 minutes, Zhiming observed a mixture of water and ice cubes in the two plastic bags.

In which set-up, A or B, would Zhiming most likely observe more ice cubes left? Give a reason for your answer.

Accepted answers:

- ✓ Set-up B
- ✓ Setup B
- ✓ B
- ✓ Set - up B

Question Type: Free Text
Date Added: Thu 5th Aug 2021
Last Modified: N/A
QID#: 28,628,131

Correctly answered feedback

Set-up B. Air is a poor conductor of heat and slowed down the heat from the surrounding to enter the bag of ice cubes in Set-up B.

Incorrectly answered feedback

Set-up B. Air is a poor conductor of heat and slowed down the heat from the surrounding to enter the bag of ice cubes in Set-up B.

[Answers](#) | [Edit](#) | [Duplicate](#) | [Used In](#) | [Reorder](#)

[Remove From Test](#)

Question 58

Primary 5 Science » Primary 5 Science (Term 2)

0 pts

One day, Zhiming sat outside a restaurant and was having his ice dessert.



At the same time, he observed another customer seated inside the restaurant having the same ice dessert as shown in the diagram below.



Zhiming observed that his ice dessert turned to liquid faster than the other customer's ice dessert. Give a reason for this observation. [1]

This question is designed for extended answers that parent/ teacher will have to assign and guide child to attempt after the test has been completed.

Grading: This question type is not graded on this system and will not affect the final score as it was designed in such a way that it requires manual assistance.

Question Type: Essay

Date Added: Thu 5th Aug 2021
 Last Modified: N/A
 QID#: 28,628,115

Correctly answered feedback

The air at outdoor seating is warmer than the air at the indoor seating thus the dessert will gain more heat at the outdoor causing te dessert to melt faster.

Incorrectly answered feedback

The air at outdoor seating is warmer than the air at the indoor seating thus the dessert will gain more heat at the outdoor causing te dessert to melt faster.

[Answers](#) | [Edit](#) | [Duplicate](#) | [Used In](#) | [Reorder](#) [Remove From Test](#)

Question 59

Primary 5 Science » Primary 5 Science (Term 2)

1 pt

On island W, there were 3 types of plants, X, Y and Z. The locations of the 3 types of plants were indicated in the diagram below.

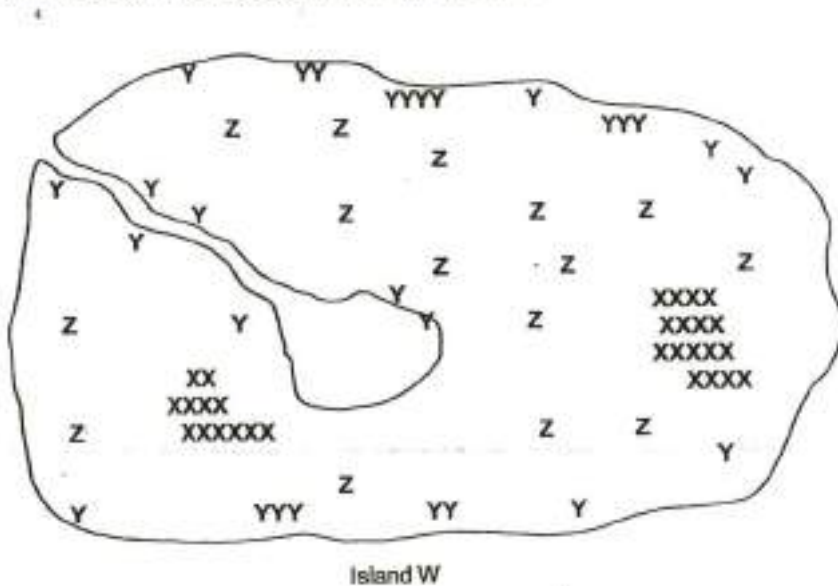

Based on the locations of the 3 types of plants on island W, state a likely physical characteristic of the fruit of Plant X which helps them in their dispersal of fruits.

Plant	Physical Characteristics of the fruit
X	

Accepted answers:

- ✓ Pod-like structure
- ✓ pod - like structure

Question Type: Free Text
 Date Added: Thu 5th Aug 2021
 Last Modified: N/A
 QID#: 28,628,130

[Answers](#) | [Edit](#) | [Duplicate](#) | [Used In](#) | [Reorder](#) [Remove From Test](#)

Question 60

Primary 5 Science » Primary 5 Science (Term 2)

1 pt

On island W, there were 3 types of plants, X, Y and Z. The locations of the 3 types of plants were indicated in the diagram below.

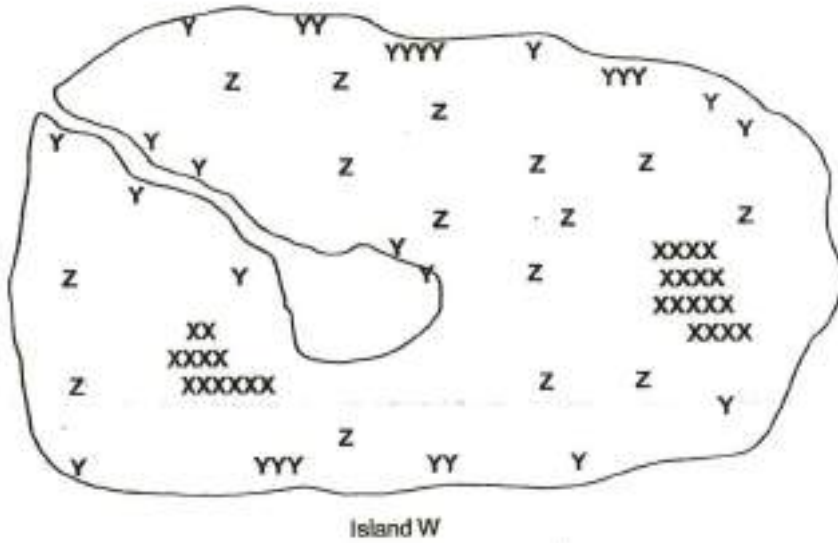

Based on the locations of the 3 types of plants on island W, state a likely physical characteristic of the fruit of Plant Y which helps them in their dispersal of fruits.

Plant	Physical characteristics of the fruit
Y	

Accepted answers:

- ✓ Fibrous husks

Question Type: Free Text
 Date Added: Thu 5th Aug 2021
 Last Modified: N/A
 QID#: 28,628,132

[Answers](#) |
 [Edit](#) |
 [Duplicate](#) |
 [Used In](#) |
 [Reorder](#)
[Remove From Test](#)

Question 61

Primary 5 Science » Primary 5 Science (Term 2)

1 pt

On island W, there were 3 types of plants, X, Y and Z. The locations of the 3 types of plants were indicated in the diagram below.

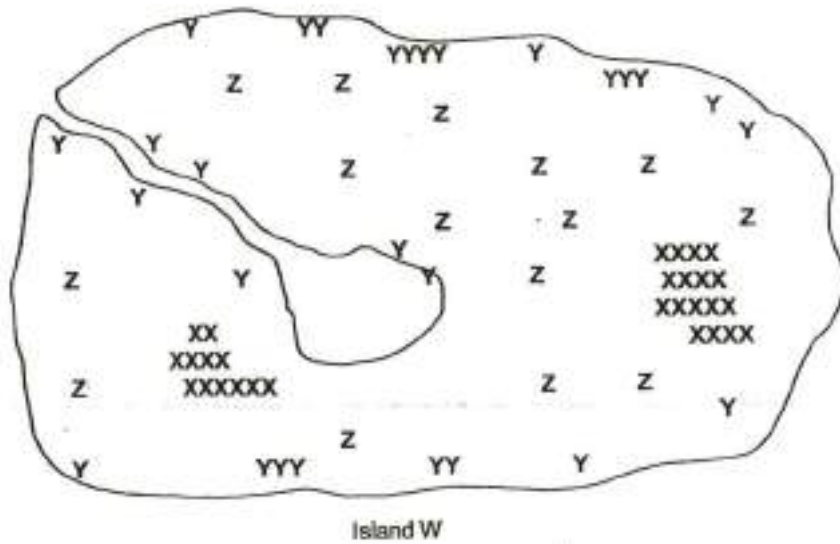

Based on the locations of the 3 types of plants on island W, state a likely physical characteristic of the fruit of Plant Z which helps them in their dispersal of fruits.

Plant	Physical Characteristics of the fruit
Z	

Accepted answers:

✓ Hooks

Question Type: Free Text
 Date Added: Thu 5th Aug 2021
 Last Modified: N/A
 QID#: 28,628,134

[Answers](#) | [Edit](#) | [Duplicate](#) | [Used In](#) | [Reorder](#)

[Remove From Test](#)

Question 62

Primary 5 Science » Primary 5 Science (Term 2)

1 pt

On island W, there were 3 types of plants, X, Y and Z. The locations of the 3 types of plants were indicated in the diagram below.

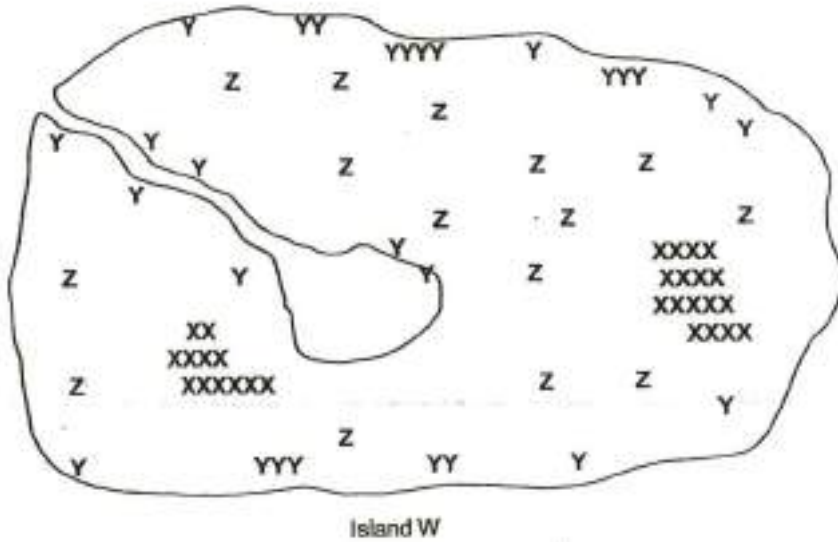

Construction works were carried out on island W and many tall buildings were built. The diagram below showed how the plants, X, Y and Z were affected.

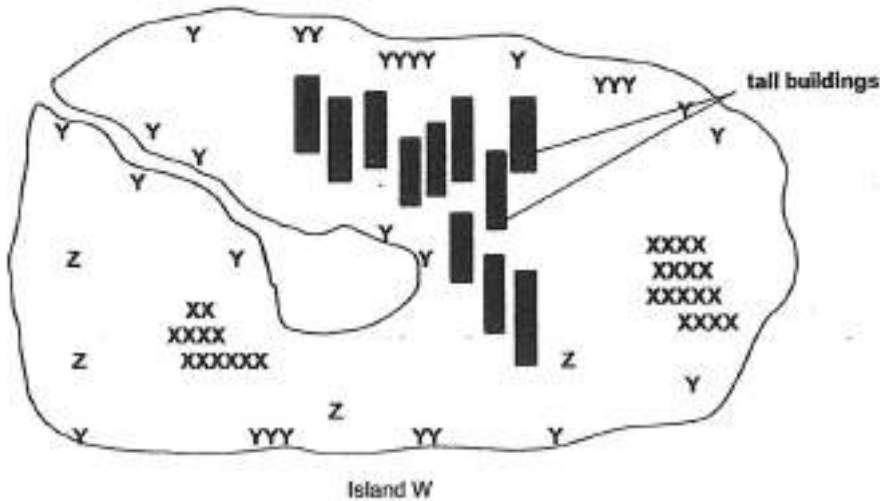

Based on the method of dispersal, which plant is most affected by the construction work on the island? Explain your answer. [1]

Accepted answers:

- ✓ Plant Z
- ✓ Z

Question Type: Free Text
 Date Added: Thu 5th Aug 2021
 Last Modified: N/A
 QID#: 28,628,135

Correctly answered feedback

Plant Z. Plant Z will disperse seeds by animals and the buildings were blocking them to get to the other side of the island.

Incorrectly answered feedback

Plant Z. Plant Z will disperse seeds by animals and the buildings were blocking them to get to the other side of the island.

[Answers](#) | [Edit](#) | [Duplicate](#) | [Used In](#) | [Reorder](#)

[Remove From Test](#)

Question 63

Primary 5 Science » Primary 5 Science (Term 2)

1 pt

The diagram below shows two types cells in the human reproductive system.

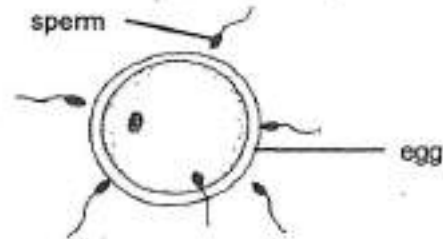

Name the organs in which the sperms are produced.

Sperms: _____

Accepted answers:

✓ Testis

Question Type: Free Text
Date Added: Thu 5th Aug 2021
Last Modified: N/A
QID#: 28,628,136

[Answers](#) | [Edit](#) | [Duplicate](#) | [Used In](#) | [Reorder](#)

[Remove From Test](#)

Question 64

Primary 5 Science » Primary 5 Science (Term 2)

1 pt

The diagram below shows two types cells in the human reproductive system.

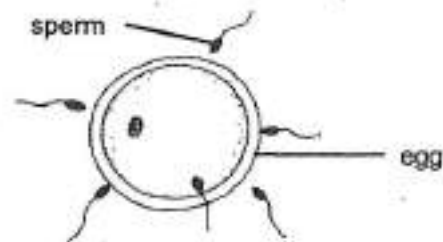

Name the organs in which the egg is produced.

Accepted answers:

✓ Ovary

Question Type: Free Text
Date Added: Thu 5th Aug 2021
Last Modified: N/A
QID#: 28,628,137

[Answers](#) | [Edit](#) | [Duplicate](#) | [Used In](#) | [Reorder](#)

[Remove From Test](#)

Question 65

Primary 5 Science » Primary 5 Science (Term 2)

1 pt

The diagram below shows two types cells in the human reproductive system.

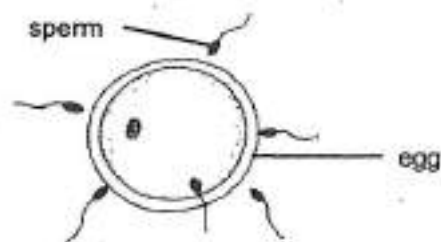

State the process shown in the diagram above.

Accepted answers:

- ✓ Fertilization
- ✓ Fertilisation

Question Type: Free Text
Date Added: Thu 5th Aug 2021
Last Modified: N/A
QID#: 28,628,138

[Answers](#) | [Edit](#) | [Duplicate](#) | [Used In](#) | [Reorder](#)

[Remove From Test](#)

Question 66

Primary 5 Science » Primary 5 Science (Term 2)

0 pts

The diagram below shows two types cells in the human reproductive system.

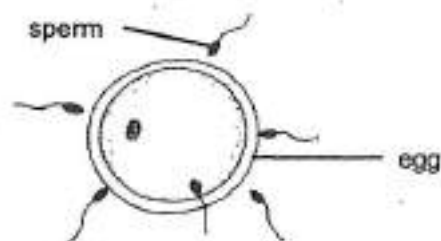

Describe what happens during the process in the previous question. (1 mark)

This question is designed for extended answers that parent/ teacher will have to assign and guide child to attempt after the test has been completed.

Grading: This question type is not graded on this system and will not affect the final score as it was designed in such a way that it requires manual assistance.

Question Type: Essay
Date Added: Thu 5th Aug 2021
Last Modified: N/A
QID#: 28,628,121

Correctly answered feedback

The sperm fuses with the egg cell.

Incorrectly answered feedback

The sperm fuses with the egg cell.

[Answers](#) | [Edit](#) | [Duplicate](#) | [Used In](#) | [Reorder](#)

[Remove From Test](#)

www.classmarker.com

